



ASYNCHRONOUS THREE-PHASE, SINGLE-PHASE AND ELECTROMAGNETIC BRAKE MOTORS

EFFICIENCY CLASS
ACCORDING TO
IEC 60034-30

2nd edition



Three-phase

IE3 Premium efficiency
IE2 High efficiency
IE1 Standard efficiency
Increased power

Single-phase

Permanent capacitor
Double capacitor
(centrifugal switch)

Three-phase with electromagnetic brake

DC brake coil
AC brake coil

Forced ventilation unit

TECHNICAL INFORMATION	Standards and specifications	4
	Efficiency standard (from 1 January 2017)	5
	Mechanical and electrical tolerances	6
	Main features	7
	Nameplate and connection diagram	8
	Mounting positions	9
	Bearings and shaft seals	11 - 13
	Motors modifications	14
	S9 duty. Frequency converter operation motors	15
	Rated service conditions	16
	Spare parts	18 - 20

	Description	Type	Series	
ELECTRICAL DATA	Asynchronous three-phase motors	IE3	IE3-MS / IE3-EG	21 - 23
		IE2	IE2-MS / IE2-EG	24 - 26
		IE1	IE1-MS / IE1-EG	27 - 30
	Asynchronous single-phase motors	Permanent capacitor	MYT / MY	31
		Double capacitor (centrifugal switch)	ML	32
	Asynchronous three-phase electromagnetic brake motors	AC brake coil	MSEFA	33 - 34
		DC brake coil	MSEFC	35 - 36

DIMENSIONS	Asynchronous three-phase motors	IE3 - Aluminium	IE3-MS	37
		IE2 - Aluminium	IE2-MS	38
		IE1 - Aluminium	IE1-MS	39
		IE3 - Cast iron	IE3-EG	40
		IE2 - Cast iron	IE2-EG	41
		IE1 - Cast iron	IE1-EG	41
	Asynchronous single-phase motors	Permanent capacitor	MYT / MY	42
		Double capacitor (centrifugal switch)	ML	43
	Asynchronous three-phase electromagnetic brake motors	AC brake coil	MSEFA	44
		DC brake coil	MSEFC	44
	Forced ventilation unit		G-D / G-B	45 - 46

	Warranties, returns and complaints	47
--	------------------------------------	----

TECHNICAL INFORMATION

STANDARDS AND SPECIFICATIONS EN AND IEC



CEMER motors are designed according to the most important European and International standards, especially to these:

STANDARD TITLE	REFERENCE	
	EN Europe	IEC International
Rotating electrical machines. Part 1: Rating and performance.	EN 60034-1	IEC 60034-1
Rotating electrical machines. Part 2-1: Standard methods for determining losses and efficiency of rotating electrical machinery from tests.	EN 60034-2-1	IEC 60034-2-1
Rotating electrical machines. Part 5: Degrees of protection provided by the integral design of rotating electrical machines (IP code). Classification.	EN 60034-5	IEC 60034-5
Rotating electrical machines. Part 6: Methods of cooling (IC Code).	EN 60034-6	IEC 60034-6
Rotating electrical machines. Part 7: Classification of types of constructions and mounting arrangements (IM Code).	EN 60034-7	IEC 60034-7
Rotating electrical machines. Part 8: Terminal markings and direction of rotation machines.	EN 60034-8	IEC 60034-8
Rotating electrical machines. Part 9: Noise limits.	EN 60034-9	IEC 60034-9
Rotating electrical machines. Part 11: Thermal protection.	-	IEC 60034-11
Rotating electrical machines. Part 12: Starting performance of single-speed three-phase cage induction motors for voltages up to and including 660 V, 50 Hz.	EN 60034-12	IEC 60034-12
Rotating electrical machines. Part 14: Mechanical vibration of certain machines with shaft height 56 mm and higher. Measurement, evaluation and limits of vibration severity.	EN 60034-14	IEC 60034-14
Rotating electrical machines. Part 30: Efficiency classes for three-phase induction cage motors of single-speed (IE Code).	-	IEC 60034-30
Thermal evaluation and designation of electrical insulation.	-	IEC 60085
IEC standard voltages.	-	IEC 60038
Three-phase induction motors of general application with normalized powers and dimensions. Frame size designation from 56 to 315.	EN 50347	IEC 60072

EFFICIENCY STANDARD

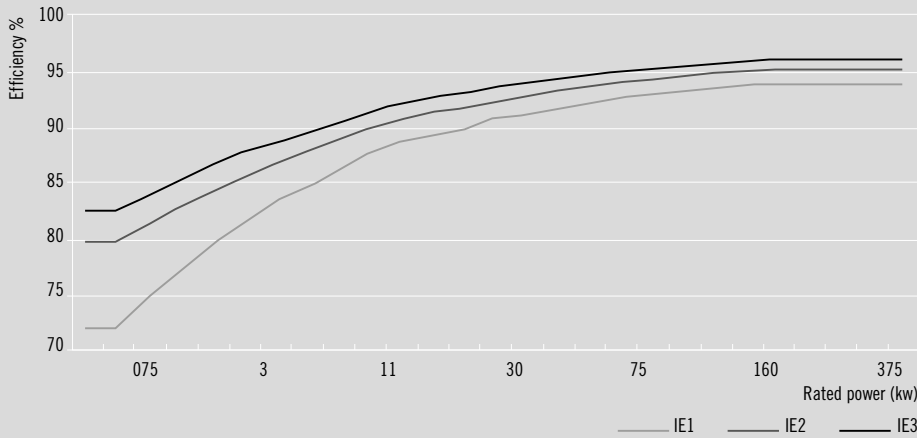

Summary (for guidance only, not binding) of the regulations in force from 1 January 2017 in accordance with Regulation (EC) n° 640/2009 of the Commission, 22 July 2009 (and subsequent amendments). Green design requirements for electric motors. The selection of the efficiency level, IE3, IE2 or IE1, is always the customer's responsibility. (*)

SCOPE OF APPLICATION (*)

Minimum efficiency level IE3

IE3

- Continuous duty operation S1 and intermittent duty S3 of 80% or greater.
- Three-phase squirrel-cage induction motors, rated voltage up to 1000 V.
- Single-speed, 2, 4 and 6 poles.
- Frequency 50Hz or 50Hz/60Hz.
- Rated output from 0.75kW to 375 kW.
- Motors operating within the EU, Norway and Switzerland.

IE2

S9 duty – When IE3 efficiency is required but motor is operated with a frequency converter, an IE2 motor can be installed.

EXCEPTIONS / MOTORS EXCLUDED FROM THE SCOPE OF APPLICATION (*)

It is important to know both the standard and its exceptions, as well as the applications outside the scope and the control of regulations.

Technical factors

- 8 poles motors (750 rpm).
- Multi-speed motors.
- Rated output up to 0.55kW.
- ATEX motors (potentially explosive atmospheres).
- Brake motors.

Application factors

- S3, S4, S5, S6... duties up to 75% SD.
- Motors designed to operate wholly immersed in a liquid.
- Motors completely integrated into a machine that cannot be tested separately.

Geographical factors

- Motors operating out of the EU.
- Altitude exceeding 4000 m above sea-level.
- Ambient temperature exceeding 60°C and less than -30°C.

(*) Summary not binding for guidance only. Please refer to the original standard.

MECHANICAL TOLERANCES

Symbol	Description	Tolerance
A	Distance between centre-lines of fixing holes (end view).	± 1 mm
AB, AC	Maximum motor width (terminal box excluded).	+ 2 %
B	Distance between centre-lines of the fixing holes (side view).	± 1 mm
C	Distance from the shoulder on the shaft to the centre-line of the mounting holes in the nearest feet.	± 3 mm
D	Outside diameter of the shaft.	k6 up to 48 mm m6 from 55 mm
E	Shaft diameter < 55 mm. Shaft diameter > 60 mm.	- 0.3 mm + 0.5 mm
F	Width of the key.	h9
GA	Distance from the top of the key to the opposite surface of shaft.	+ 0.2 mm
H	Distance from the centre-line of the shaft to the bottom of the feet.	- 0.5 \leq 250 mm - 1 \geq 280 mm
HD	Overall height (from the lowest to highest part).	+ 2 %
K, S	Diameter of fixing holes, feet or flange.	+ 3 %
L	Overall length.	+ 1 %
M	Distance between flange mounting holes.	± 0.8 mm
N	Diameter of the spigot.	j6 up to 230 mm h6 from 250 mm
P	Outside diameter of the flange.	-1 mm
	Distance from the mounting surface of the flange to the shoulder on the shaft, with blocked bearing.	± 0.5 mm
	Distance from the mounting surface of the flange to the shoulder on the shaft.	± 3 mm
m	Motor weight.	From - 5 to + 10 %

ELECTRICAL TOLERANCES

Electrical parameters according to the EN 60034-1 standard:

Efficiency (η) (Indirect measurement)	- 0.15 (1- η) for $P_N \leq 150$ kW - 0.1 (1- η) for $P_N > 150$ kW
Power factor ($\cos \varphi$)	$\frac{1-\cos\varphi}{6}$ minimum 0.02 maximum 0.07
Slip (rpm) (At rated temperature and load)	$\pm 20\%$ for $P_N \geq 1$ kW $\pm 30\%$ for $P_N < 1$ kW
Starting current (I_A)	+ 20% (without lower limit)
Starting torque (M_A)	-15% and +25%
Rated torque (M_K) (maximum)	10% (for this MK value / Mn must be of at least 1.6)
Minimum torque (M_S)	-15%
Moment of inertia (J)	$\pm 10\%$
Sound level (sound pressure)	+3 dB (A)

MAIN FEATURES

CEMER asynchronous three-phase and single-phase motors are designed according to IEC 60034, IEC 60038 and IEC 60072; frame sizes 56 - 355; power 0.06 kW - 315 kW suitable for continuous operation (S1) at rated voltage and frequency values; ambient temperature up to 40 °C and height above sea level ≤ 1,000 m. Single-speed of 2, 4, 6 and 8 poles at 230/400 V or 400/690 V 50 Hz and 230 V 50 Hz. Insulating class F, temperature rise class B. IP 55 protection, which ensures protection against dust and low-pressure water jets from any direction.

Part	Material	MS / MYT / MY / ML / MSEF series	EG series
• Housing	<ul style="list-style-type: none"> Aluminium (MS / MYT / MY / ML / MSEF series) Cast iron (EG series) 	<ul style="list-style-type: none"> Pressure die-cast aluminium Removable feet Eyebolt frame size ≥ 100 Earth terminal 	<ul style="list-style-type: none"> Cast iron Eyebolt Earth terminal
• Shields and flanges	<ul style="list-style-type: none"> Aluminium (MS / MYT / MY / ML / MSEF series) Cast iron (EG series) 	<ul style="list-style-type: none"> Pressure die-cast aluminium Bearing housing with steel insert 	<ul style="list-style-type: none"> Cast iron Relubrication device
• Stator	<ul style="list-style-type: none"> Cold-rolled magnetic sheet Electrolytic cooper 	<ul style="list-style-type: none"> Made in vacuum with double impregnation and pressurized with synthetic resins (VIP) 	<ul style="list-style-type: none"> Made in vacuum with double impregnation and pressurized with synthetic resins (VIP) PTC thermistors
• Terminal box	<ul style="list-style-type: none"> Aluminium (MS / MSEF series) Cast iron (EG series) Plastic or aluminium (ML / MYT / MY series) 	<ul style="list-style-type: none"> Adjustable 360° With cable gland Earth terminal inside 	<ul style="list-style-type: none"> Adjustable 360° With cable glands Earth terminal inside
• Rotor	<ul style="list-style-type: none"> Cold-rolled magnetic sheet Aluminium 	<ul style="list-style-type: none"> Dynamically balanced (half key) Hot mounting on the shaft 	<ul style="list-style-type: none"> Dynamically balanced (half key) Hot mounting on the shaft with driving key
• Shaft	<ul style="list-style-type: none"> Steel 	<ul style="list-style-type: none"> Front threaded hole Round key 	<ul style="list-style-type: none"> Front threaded hole Round key
• Bearings		<ul style="list-style-type: none"> Ball bearings with double rubber sealing and lubricated for life DE preloaded 	<ul style="list-style-type: none"> Open ball bearings with external relubrication device DE preloaded
• Shaft seals	<ul style="list-style-type: none"> Synthetic rubber 	<ul style="list-style-type: none"> Shaft seals on both sides for all frame sizes 	<ul style="list-style-type: none"> Shaft seals on both sides for all frame sizes
• Fan	<ul style="list-style-type: none"> Thermoplastic or aluminium (as option) 	<ul style="list-style-type: none"> Radial bi-directional blades 	<ul style="list-style-type: none"> Radial bi-directional blades
• Fan cover	<ul style="list-style-type: none"> Steel sheet 	<ul style="list-style-type: none"> V5, V15, V1 and V18 vertical shaft down position, with rain canopy (as option) 	<ul style="list-style-type: none"> V5, V15, V1 position (vertical shaft down) with rain canopy (as option)
• Painting	<ul style="list-style-type: none"> Standard paint 	<ul style="list-style-type: none"> Blue colour, RAL 5010 (MS IE1, IE2 series) Umbra grey colour, RAL 7022 (MS IE3 series) Black colour, RAL 9005 (MY / MYT / ML series) Grey colour, RAL 9006 (MSEF series) 	<ul style="list-style-type: none"> Blue colour, RAL 5010 (EG IE1, IE2 series) Umbra grey colour, RAL 7022 (EG IE3 series)

NAMEPLATE

Each motor is identified with an indicator plate including the technical details required by the IEC 60034-30:2008 standard. The plate is aluminium or steel depending on the series and is fitted on the side or top of the motor frame.

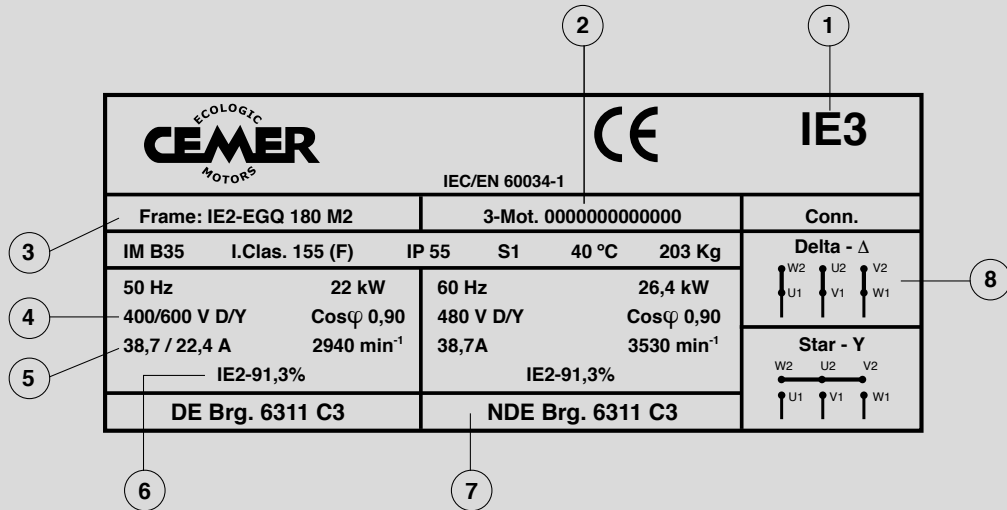

1 Efficiency class (IE1, IE2, IE3)

2 Serial number

3 Type (IE2-EGQ 180M 2): efficiency level (IE2), series (EGQ), frame size (180M) and number of poles (2)

4 Rated voltage at 50 Hz

5 Rated current at 50 Hz

6 IE efficiency class and 100% of load rated efficiency at 50 Hz

7 Type of bearings

8 Connection diagram (for motors frame size ≥ 160)

CONNECTION DIAGRAM

Single-speed three-phase motor

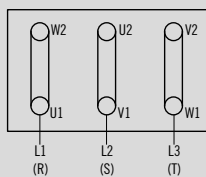

Low voltage (Δ)

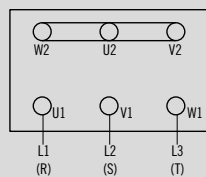

High voltage (Y)

MS / EG / MSEF series

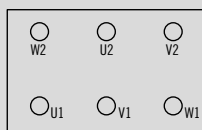

For star-delta switch without connection bridges, connection must be done according to the supplier's diagram.

Starter (Y - Δ)

Single-phase motor

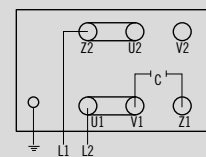

Clockwise

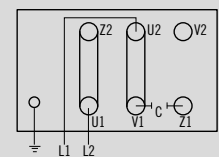

Anti-clockwise

Single-phase motor

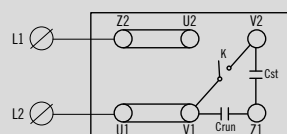

Clockwise

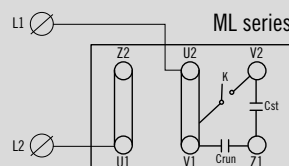

Anti-clockwise

Electromagnetic brake motors (MSEF series), when powered with a frequency converter, need an independent brake connection from the motor. Please contact to Cosgra for the connection diagram.

MOUNTING POSITIONS

CEMER motors from 56 to 355 can be supplied according to the mounting positions of the following table. Basic types of mounting are designated according to EN 60034-7. Motors mounted in IM B3, IM B5 or IM B14 can also be mounted in different positions.

IM B3 in IM V5, IM V6, IM B6, IM B7, IM B8.

IM B35 in IM V15, IM V36, IM 2051, IM 2061, IM 2071.

IM B34 in IM 2111, IM 2131, IM 2151, IM 2161, IM 2171.

IM B5 in IM V1 and IM V3. (Through-holes flange).

IM B14 in IM V18 and IM V19. (Threaded holes flange).

For any mounting position frame size 160-355, specially for IM V5, IM V6, IM B6, IM B7 and IM B8 types, please contact to Cosgra.

Positions IM B5 and IM V3 cannot be used for motors 315 and 355. For frame size 280 please contact to Cosgra.

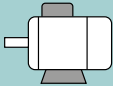
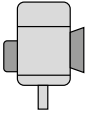
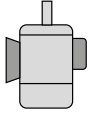
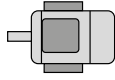
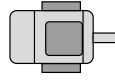
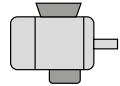
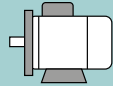
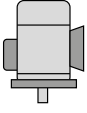
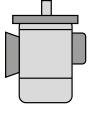
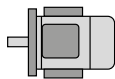
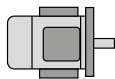
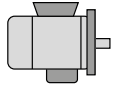
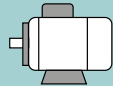
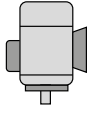
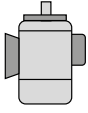
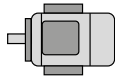
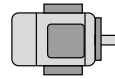
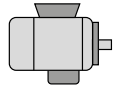
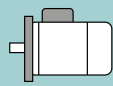
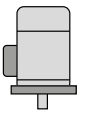
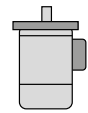
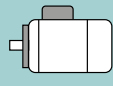
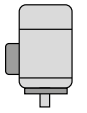
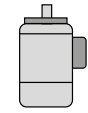
Basic mounting positions	Other mounting positions				
<p>IM B3 IM 1001</p> 	<p>IM V5 IM 1011</p> 	<p>IM V6 IM 1031</p> 	<p>IM B6 IM 1051</p> 	<p>IM B7 IM 1061</p> 	<p>IM B8 IM 1071</p> 
<p>IM B35 IM 2001</p> 	<p>IM V15 IM 2011</p> 	<p>IM V36 IM 2031</p> 	<p>- IM 2051</p> 	<p>- IM 2061</p> 	<p>- IM 2071</p> 
<p>IM B34 IM 2101</p> 	<p>- IM 2111</p> 	<p>- IM 2131</p> 	<p>- IM 2151</p> 	<p>- IM 2161</p> 	<p>- IM 2171</p> 
<p>IM B5 IM 3001</p> 	<p>IM V1 IM 3011</p> 	<p>IM V3 IM 3031</p> 			
<p>IM B14 IM 3601</p> 	<p>IM V18 IM 3611</p> 	<p>IM V19 IM 3631</p> 			

MS / MYT / MY / ML / MSEF

MOTOR SERIES



BEARINGS

MS / MYT / MY / ML / MSEF motor series are delivered as standard with deep groove ball bearings with double rubber sealing, lubricated for life and maintenance-free.

Motor		Bearing	
Frame size	Poles	DE	NDE
56	2-4-6-8	6201 2RS C3	6201 2RS C3
63	2-4-6-8	6201 2RS C3	6201 2RS C3 (** 6202 2RS C3)
71	2-4-6-8	6202 2RS C3	6202 2RS C3 (** 6203 2RS C3)
80	2-4-6-8	6204 2RS C3	6204 2RS C3
90	2-4-6-8	6205 2RS C3	6205 2RS C3 (6204 2RS C3*)
100	2-4-6-8	6206 2RS C3	6206 2RS C3
112	2-4-6-8	6306 2RS C3	6306 2RS C3 (** 6207 2RS C3)
132	2-4-6-8	6308 2RS C3	6308 2RS C3
160	2-4-6-8	6309 2RS C3	6309 2RS C3

* Bearing in parenthesis refers to MYT / MY / ML single-phase motors.

** Bearing in parenthesis refers to MSEF electromagnetic brake motors.

SHAFT SEALS

MS / MYT / MY / ML / MSEF series are delivered with spring-loaded double-lip seal to enhance motor sealing efficiency.

Motor		Shaft seal	
Frame size	Poles	DE	NDE
56	2-4-6-8	12x22x5	12x22x5
63	2-4-6-8	12x24x5	12x24x5
71	2-4-6-8	15x25x7	15x25x7
80	2-4-6-8	20x34x7	20x34x7
90	2-4-6-8	25x37x7	25x37x7 (20x34x7*)
100	2-4-6-8	30x44x7	30x44x7
112	2-4-6-8	30x44x7	30x44x7
132	2-4-6-8	40x58x7	40x58x7
160	2-4-6-8	45x65x8	45x65x8

* Shaft seal in parenthesis refers to MYT / MY / ML single-phase motors.

Note: Bearings and shaft seals dimensions change depending on the motor series. For further information please contact to Cosgra. Data for MSE series.

EG

MOTOR
SERIES



BEARINGS

EG motor series are delivered with bearings suitable for direct coupling and horizontal operation.

They are deep groove ball bearings, open and have a single row. They need to be lubricated with lithium-based grease suitable for bearings. **EG** cast iron motors are designed with an external lubrication system.

Motor		Bearing		
Frame size	Poles	DE	NDE	Lubrication hours/cm ³
160	2-4-6-8	6309 C3	6309 C3	2000 - 4000 / 20-20
180	2-4-6-8	6311 C3	6311 C3	2000 - 4000 / 23-23
200	2-4-6-8	6312 C3	6312 C3	2000 - 4000 / 31-31
225	2	6312 C3	6312 C3	2000 / 31-31
	4-6-8	6313 C3	6312 C3	4000 / 35-31
250	2	6313 C3	6313 C3	2000 / 35-35
	4-6-8	6314 C3	6313 C3	4000 / 41-35
280	2	6314 C3	6314 C3	2000 / 41-41
	4-6-8	6317 C3	6314 C3	4000 / 57-41
315	2	6317 C3	6317 C3	2000 / 57-57
	4-6-8	6319 C3	6319 C3	4000 / 64-64
355	2	6319 C3	6319 C3	2000 / 64-64
	4-6-8	6322 C3	6322 C3	3000 / 78-78

SHAFT SEALS

EG motors series are delivered with spring-loaded double-lip seal to enhance motor sealing efficiency.

Motor		Shaft seal	
Frame size	Poles	DE	NDE
160	2-4-6-8	45x62x8	45x62x8
180	2-4-6-8	55x72x8	55x72x8
200	2-4-6-8	60x80x8	60x80x8
225	2	65x85x10	60x80x8
	4-6-8	65x90x10	60x80x8
250	2-4-6-8	70x90x10	65x85x10
280	2	70x90x10	70x90x10
	4-6-8	85x110x12	70x90x10
315	2	85x110x12	85x110x12
	4-6-8	95x120x12	95x120x12

Note: Bearing and shaft seals dimensions change depending on the motor series. For further information, please contact to Cosgra. Data for EGQ series.

MOTORS MODIFICATIONS

BELT/PULLEY TRANSMISSION (*)

Transmission elements need to be selected carefully in order to ensure a good performance of the motor. Please contact your supplier of belts, pulleys and couplings or our technical department.

When a motor is driven by belt/pulley, there's a high radial force on the motor's shaft, which is transmitted to the DE bearing. For motors from frame size IEC-56 to 250 (included) the magnitude of this force is not important and it can be used a standard bearing.

Motors from frame size IEC-160 to 355 need a cylindrical roller bearing (NU-type), which is selected depending on the application. Following information about pulley will be required:

- | | |
|------------------------|----------------------|
| -Weight (Kg) | -Outer diameter (mm) |
| -Number of grooves (N) | -Width (mm) |

IMPORTANT. Cylindrical roller bearings (NU) must always support at least 25% of their maximum radial load in order to ensure their correct operation. In many cases, the weight of the element supported by the bearing, together with the external forces, is greater than the minimum required load.

VERTICALLY MOUNTED MOTORS – SHAFT UP (*)

Mounting positions: B3-V6, B35-V36, B34-IM 2131, B5-V3 and B14-V19 (see page 9).

Motors are designed to work horizontally, and when they work vertically –shaft up-, the DE bearing (the one in upper position) supports the shaft and rotor weight, which means a higher axial force than estimated.

For motors from frame size IEC-56 to 250 (included) the magnitude of this force is not important and it can be used a standard bearing.

For motors of frame size IEC-280, 315 and 355 an angular contact ball bearing (QJ/7000 type) must be installed at DE.

VERTICALLY MOUNTED MOTORS – SHAFT DOWN (*)

Mounting positions: B3-V5, B35-V15, B34-IM 2111, B5-V1 and B14-V18 (see page 9).

Motors are designed to work horizontally, and when they work vertically -shaft down-, the NDE bearing (the one in upper position) supports the shaft and rotor weight, which means a higher axial force than estimated.

For motors from frame size IEC-56 to 250 (included) the magnitude of this force is not important and it can be used a standard bearing.

For motors of frame size IEC-280, 315 and 355 an angular contact ball bearing (QJ/7000 type) must be installed at NDE.

(*) This information is not binding. Please contact to Cosgra to study your application.

PROTECTION SYSTEMS

On request, motors with following protection systems can be supplied:

- PTC thermistors in the winding (on request; from frame size 160 included).
- Temperature bimetallic thermistors (klixon), normally closed NC or normally open NO.
- PT100 thermistors in bearings and winding.
- Anti-condensation heaters in winding.

S9 DUTY FREQUENCY CONVERTER OPERATION MOTORS (**)

All **CEMER** motors can be powered by a frequency converter, but always bearing in mind the following technical requirements.

If the customer does not take precautions in the design of the electrical system, motors manufactured with standard insulation can fail and break down. Voltage peaks on the motor's terminals can have very great amplitude and last for a long time. Depending on the type, length and configuration of the motor's cabling, impulses can be as much as double the voltage of the frequency changer link.

If the exchanger link voltage does not exceed 600 V, **CEMER** motors can operate with a frequency changer with output voltage up to 420 V without any kind of subsequent filter. It is recommended to order motors, if possible, with a star (Y) connection.

COSGRA recommends motors with an insulated protection system from frame size 280 (included) to avoid damages of residual currents.

Motors are just one complex part of an electrical drive system. Nowadays the frequency changer protects itself and the motor against thermal overload, but it will not detect the excess voltage peaks on the motor terminals. For the drive system, the problems can increase in the absence of frequency changer output filters and/or with excessively long cables. This often causes serious damage to the motor insulation.

There are various options for optimising the electrical drive system:

- Frequency changer output filter circuits (choke, du/dt, sine).
- Motor with reinforced insulation system.
- Combination of both the above.

The person responsible for the study must carefully select the different components of the system. That person is responsible for ensuring the voltage in the motor terminals does not exceed the permitted values. This also includes selecting the motor insulation system, always bearing in mind the effects of the other components of the whole.

To compensate for loss of performance of the motor due to the frequency converter, it is appropriate to use a service factor of 1.1 or above.

It is highly recommended to install temperature thermistors in the winding to prevent the motor overheating.

Sometimes forced ventilation is needed. See pages 45 and 46.

We have a technical department specialising in this kind of application who can advise you on selecting the motor correctly, depending on the application.

(**) Non-binding information. Please contact to Cosgra to study your application.

RATED SERVICE CONDITIONS

POWER

Rated output specified in this catalogue meet EN 60034-1, for which an ambient temperature of up to 40 °C and a height above sea level of $\leq 1,000$ m are assumed. The admissible overloads are 10% for the maximum temperature of 40 °C or rated output up to 2,500 m above sea level.

In atmospheres with temperatures above the maximum, or at heights of more than 1,000 m above sea level, it is possible to operate with the motors provided if the rated output is reduced in accordance with the following tables:

Ambient temperature °C		40	45	50	55	60	
Power %		100	97	93	87	82	
Altitude above sea level	1000	1500	2000	2500	3000	3500	4000
Power %	100	98	95	91	87	83	78

VOLTAGES AND FREQUENCIES

The motors are designed to be able to operate in the rated voltage and frequency conditions with the tolerances indicated in the diagram.

The motors can operate within the area of normal use, zone A, without reduction of the rated output and with voltage variations of $\pm 5\%$ of the design value and frequency variation of $\pm 2\%$.

In addition, the motors can also work in the area of restricted use, zone B, with voltage variations of $\pm 10\%$ and a frequency of $\pm 3\%$, always following the indications required in the EN 60034-1 standard.



1. A zone, normal use area
2. B zone, restricted use area
3. Rating point, rated features

X = Frequency ratio, f/f_N

$$f/f_N = \frac{\text{Operation frequency}}{\text{Rated frequency}}$$

Y = Voltage ratio, U/U_N

$$U/U_N = \frac{\text{Operation voltage}}{\text{Rated voltage}}$$

Standard motors are delivered with following voltage and frequency values:

230/400 V	Δ/Y	50 Hz	275/480 V	Δ/Y	60 Hz
400/690 V	Δ/Y	50 Hz	480 V	Δ	60 Hz

On request, other voltages and frequencies can be supplied.

OVERLOAD CAPACITY

In accordance with EN 60034-1 standard, all motors can be submitted to the following overload conditions at rated frequency and voltage:

- 1.5 times the rated intensity for 2 minutes.
- 1.6 times the rated torque for 15 seconds ($1.5 \text{ times } I_A/I_N < 4.5$).



SPARE PARTS

Aluminium motor **MS / MYT / MY / ML / MSEF** series, Frame size 56-160.

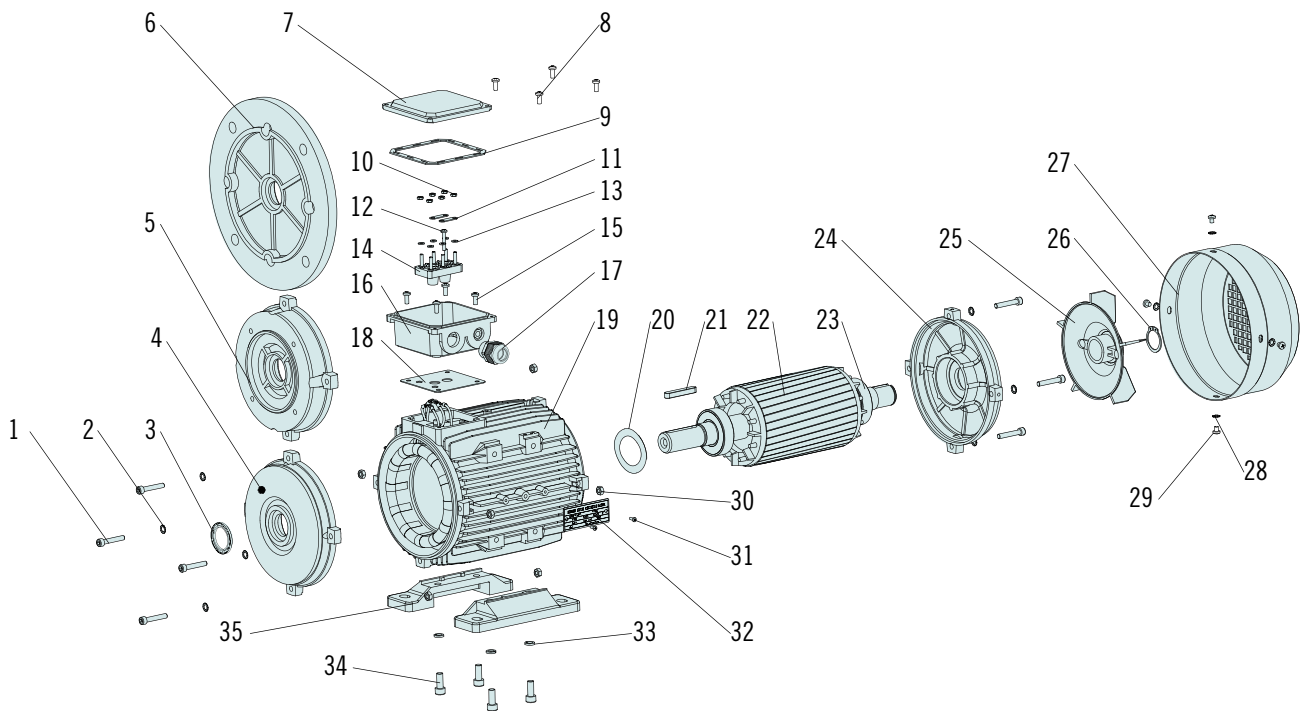

- | | | |
|----------------------------|------------------------------|--------------------|
| 1 DE shield screw | 15 Terminal plate base screw | 29 Fan cover screw |
| 2 Washer | 16 Terminal box base | 30 NDE shield nut |
| 3 Shaft seal | 17 Cable gland | 31 Rivet |
| 4 DE shield | 18 Terminal box base seal | 32 Nameplate |
| 5 B14 flange | 19 Stator (housing) | 33 Wave washer |
| 6 B5 flange | 20 Wave washer | 34 Feet screw |
| 7 Terminal box cover | 21 Shaft key | 35 Feet |
| 8 Terminal box cover screw | 22 Rotor + shaft | |
| 9 Terminal box seal | 23 NDE bearing | |
| 10 Terminal box nut | 24 NDE shield | |
| 11 Connecting bridges | 25 Fan | |
| 12 Terminal box screw | 26 Circlip | |
| 13 Flat washer | 27 Fan cover | |
| 14 Terminal plate | 28 Grower washer | |

* Spare parts change depending on the motor series. Please contact us for more information. MSE series spare parts.
When ordering a capacitor (MY/MYT/ML series), please specify the motor type and the number of microfarads.
Brake motors MSEF series: possibility to purchase the full brake kit or individual spare parts (see page 20).

Cast iron motor **EG** series,
Frame size 160-355.

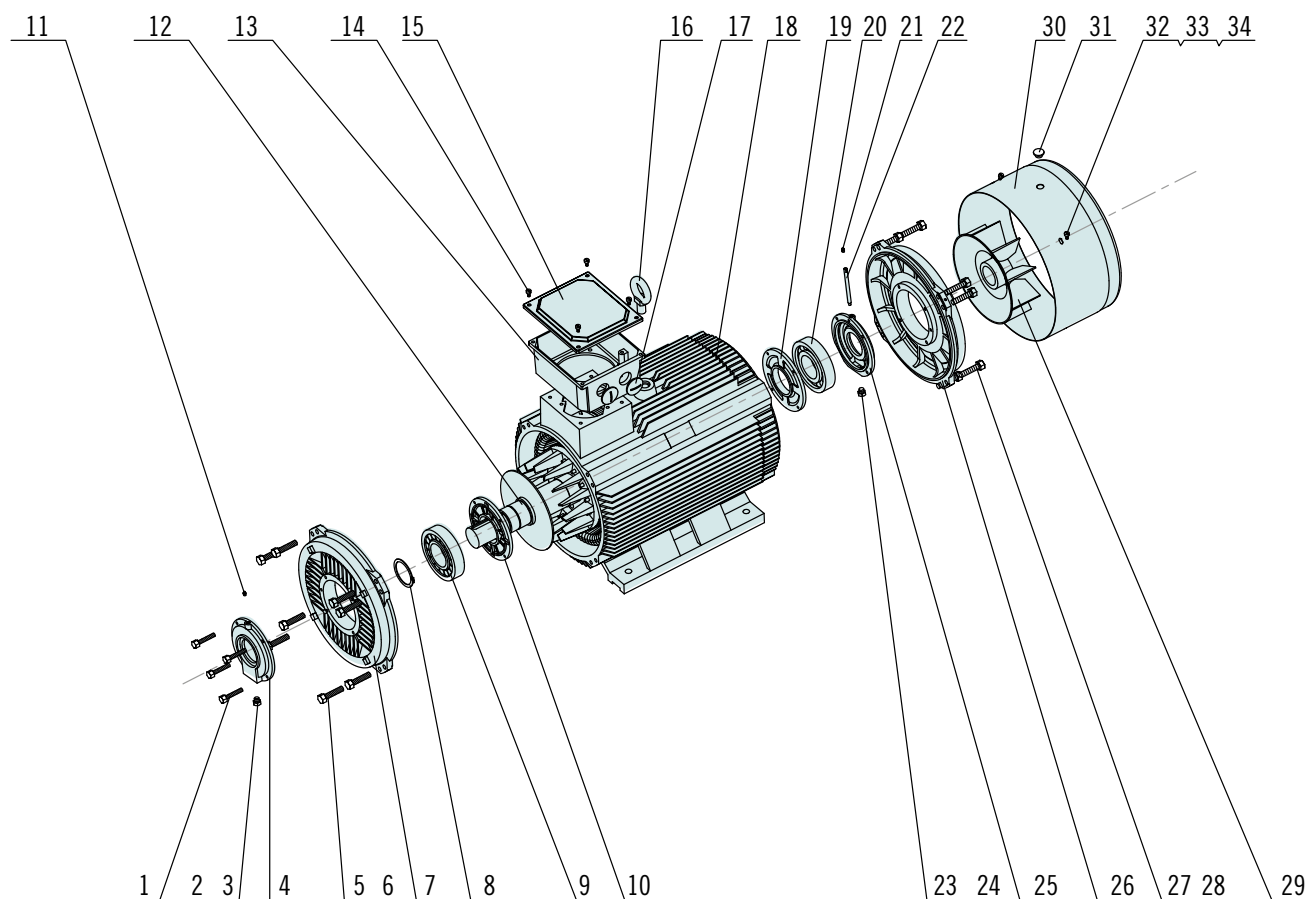

- 1 DE cover fixing screw
- 2 Lubrication cap
- 3 Washer
- 4 DE outer cover bearing
- 5 DE shield screw
- 6 Grower washer
- 7 DE shield
- 8 Circlip
- 9 DE bearing
- 10 DE inner cover bearing
- 11 Lubrication
- 12 Rotor + shaft
- 13 Terminal box base
- 14 Terminal box cover screw

- 15 Terminal box cover
- 16 Eyebolt
- 17 Cable gland
- 18 Stator (housing)
- 19 NDE inner cover bearing
- 20 NDE bearing
- 21 Lubrication device
- 22 Lubrication pipe
- 23 Lubrication cap
- 24 Washer
- 25 NDE outer cover bearing
- 26 NDE shield
- 27 NDE shield screw
- 28 Grower washer

- 29 Fan
- 30 Fan cover
- 31 Cap
- 32 Fan cover screw
- 33 Flat washer
- 34 Grower washer

* Spare parts change depending on the motor series. Please contact us for more information. EGQ series spare parts.

BRAKE SYSTEM

Electromagnetic brake motors,
MSEFA / MSEFC series, Frame size 63-160.



Brake system spare parts

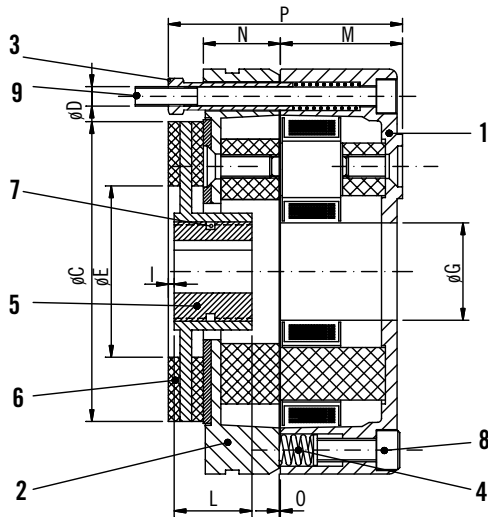

MSEFA series
AC brake system
(Connection 230/400V 50Hz III)

- 1 Electromagnet
- 2 Armature plate
- 3 Adjusting screw
- 4 Torque spring
- 5 Brake hub
- 6 Brake disc
- 7 O-ring
- 8 Brake torque adjusting screw
- 9 Fixing screws

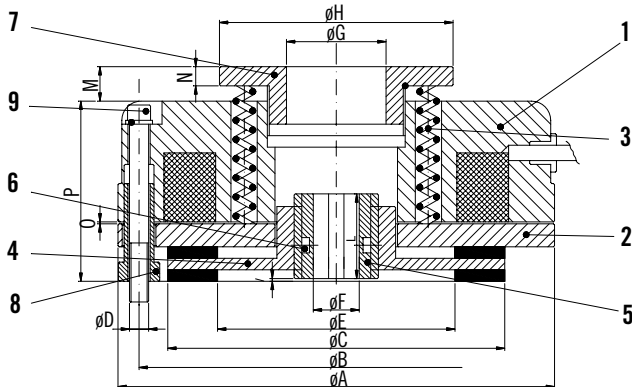

MSEFC series
DC brake system
(Single-phase connection 230V
through rectifier 110V DC)

- 1 Electromagnet
- 2 Armature plate
- 3 Torque spring
- 4 Brake disc
- 5 Brake hub
- 6 O-ring
- 7 Adjusting ring
- 8 Adjusting nut
- 9 Fixing screws

ELECTRICAL DATA

EFFICIENCY
IE3 - 3000 rpm

ASYNCHRONOUS THREE-PHASE MOTORS

Squirrel-case rotor.
External cooling IC 411, continuous duty S1.
Insulation class 155 (F), protection degree IP55.

Aluminium motors **IE3-MS** series.
Cast iron motors **IE3-EG** series.

Synchronous speed 3000 rpm - 2 poles

400 V. 50 Hz

TYPE	Power		M _n N.m	n rpm	IE3 efficiency class EN 60034-2-1			I _n 400 V A	I _x /I _n	Cosφ	M _x /M _n	M _k /M _n	J Kg·m ²	Noise level dB(A)	m Kg		
	kW	hp			100%	75%	50%										
Aluminium motors IE3-MS series (**)	IE3 - MS 80 1	-	0.75	1	2.50	2850	80.7	81.0	79.5	1.62	8.0	0.83	2.2	2.0	0.000972	67	10.4
	IE3 - MS 80 2	-	1.1	1.5	3.65	2860	82.7	83.0	83.3	2.35	8.0	0.83	2.2	2.0	0.001275	67	13.3
	IE3 - MS 90 S	-	1.5	2	4.98	2860	84.2	84.4	84.2	3.11	8.0	0.83	2.2	2.2	0.002186	72	15.4
	IE3 - MS 90 L1	-	2.2	3	7.31	2860	85.9	86.1	85.1	4.38	8.5	0.85	2.2	2.2	0.002636	72	16.7
	IE3 - MS 100 L1	-	3	4	9.90	2880	87.1	87.3	86.9	5.80	8.5	0.86	2.2	2.2	0.004842	76	25.9
	IE3 - MS 112 M	-	4	5.5	13.19	2880	88.1	88.3	87.2	7.65	8.5	0.86	2.2	2.2	0.007505	77	34.4
	IE3 - MS 132 S1	-	5.5	7.5	18.08	2890	89.2	89.4	88.1	10.10	8.5	0.88	2.2	2.2	0.015212	80	45.0
	IE3 - MS 132 S2	-	7.5	10	24.48	2910	90.1	90.3	90.7	13.70	8.5	0.88	2.2	2.2	0.018996	80	61.3
	IE3 - MS 160 M1	-	11	15	35.67	2930	91.2	91.4	89.5	19.40	8.5	0.90	2.2	2.2	0.059613	86	86.3
	IE3 - MS 160 M2	-	15	20	48.47	2940	91.9	92.2	90.2	26.30	8.5	0.90	2.2	2.2	0.076751	86	101.4
	IE3 - MS 160 L	-	18.5	25	59.78	2940	92.4	92.6	90.8	31.90	8.5	0.91	2.2	2.2	0.092252	86	119.7
Cast iron motors IE3-EG series	IE3 - EG 160 M1	-	11	15	35.73	2940	91.2	91.1	89.6	19.6	7.7	0.89	2.2	2.3	0.0437	79	145
	IE3 - EG 160 M2	-	15	20	48.72	2940	91.9	91.8	90.4	26.5	7.8	0.89	2.2	2.3	0.0554	79	160
	IE3 - EG 160 L	-	18.5	25	60.09	2940	92.4	92.3	91.0	32.5	7.8	0.89	2.0	2.3	0.0638	79	175
	IE3 - EG 180 M	-	22	30	71.22	2950	92.7	92.6	91.3	38.5	7.3	0.89	2.0	2.3	0.0922	80	215
	IE3 - EG 200 L1	-	30	40	96.79	2960	93.3	93.2	92.0	52.1	7.4	0.89	2.0	2.3	0.1571	82	290
	IE3 - EG 200 L2	-	37	50	119.40	2960	93.7	93.6	92.5	64.0	7.4	0.89	2.0	2.3	0.1691	82	310
	IE3 - EG 225 M	-	45	60	144.70	2970	94.0	93.9	92.9	77.6	7.4	0.89	2.0	2.3	0.3161	84	390
	IE3 - EG 250 M	-	55	75	176.90	2970	94.3	94.2	93.3	94.6	6.9	0.89	2.2	2.3	0.3595	80	520
	IE3 - EG 280 S	-	75	100	240.40	2980	94.7	94.6	93.7	128	6.9	0.89	2.0	2.3	0.6682	81	680
	IE3 - EG 280 M	-	90	125	288.40	2980	95.0	94.9	94.0	154	7.0	0.89	2.0	2.2	0.7770	81	725
	IE3 - EG 315 S	-	110	150	352.50	2980	95.2	95.1	94.2	185	7.0	0.90	2.0	2.2	1.4572	84	940
	IE3 - EG 315 M	-	132	180	423.00	2980	95.4	95.3	94.4	222	7.1	0.90	2.0	2.2	1.6059	84	1050
	IE3 - EG 315 L1	-	160	220	512.80	2980	95.6	95.5	95.0	265	7.1	0.91	2.0	2.2	2.0817	84	1130
	IE3 - EG 315 L2	-	200	270	640.90	2980	95.8	95.7	95.0	331	7.1	0.91	2.0	2.2	2.3791	84	1195
	IE3 - EG 355 M	-	250	340	801.20	2980	95.8	95.7	95.0	414	7.1	0.91	2.0	2.2	4.3834	85	on request
IE3 - EG 355 L1	-	315	430	1009.00	2980	95.8	95.7	95.0	522	7.0	0.91	1.7	2.2	4.7205	85	on request	
IE3 - EG 355 L2	-	355	480	1138.00	2980	95.8	95.7	95.0	588	7.2	0.91	1.7	2.2	6.7758	85	on request	

* Electrical data change depending on the series. For further information, please contact to Cosgra. MSE and EGQ data.

** Cast iron motors available for frame sizes 80 -132 (other powers and values on request).

ASYNCHRONOUS THREE-PHASE MOTORS

Squirrel-case rotor.
 External cooling IC 411, continuous duty S1.
 Insulation class 155 (F), protection degree IP55.

Aluminium motors **IE3-MS** series.
 Cast iron motors **IE3-EG** series.

Synchronous speed 1500 rpm - 4 poles

400 V. 50 Hz

TYPE	Power		M _n N.m	n rpm	IE3 efficiency class EN 60034-2-1			I _n 400 V A	I _x /I _n	Cosφ	M _x /M _n	M _r /M _n	J Kg·m ²	Noise level dB(A)	m Kg
	kW	hp			100%	75%	50%								
	Aluminium motors IE3-MS series														
IE3 - MS 80 2	0.75	1	5.13	1390	82.5	82.7	78.8	1.69	8.0	0.78	2.2	2.2	0.002285	58	12.8
IE3 - MS 90 S	1.1	1.5	7.52	1390	84.1	84.4	80.1	2.40	8.0	0.79	2.2	2.2	0.003842	61	16.2
IE3 - MS 90 L	1.5	2	10.18	1400	85.3	85.5	81.4	3.19	8.0	0.80	2.2	2.2	0.004685	61	19.2
IE3 - MS 100 L1	2.2	3	14.82	1410	86.7	86.9	86.2	4.60	8.0	0.80	2.2	2.2	0.008754	64	25.0
IE3 - MS 100 L2	3	4	20.07	1420	87.7	87.8	86.9	6.12	8.5	0.81	2.2	2.2	0.011063	64	29.5
IE3 - MS 112 M	4	5.5	26.57	1430	88.1	88.3	88.4	8.02	8.5	0.82	2.2	2.2	0.015292	65	37.8
IE3 - MS 132 S	5.5	7.5	36.28	1440	89.6	89.7	89.3	10.80	8.5	0.83	2.2	2.2	0.034464	71	58.8
IE3 - MS 132 M	7.5	10	49.14	1450	90.4	90.6	91.6	14.30	8.5	0.84	2.2	2.2	0.043597	71	68.2
IE3 - MS 160 M	11	15	71.58	1460	91.4	91.6	91.8	20.30	8.5	0.86	2.2	2.2	0.105373	75	96.8
IE3 - MS 160 L	15	20	97.60	1460	92.1	92.5	91.9	27.20	8.5	0.87	2.2	2.2	0.137038	75	111.4
Cast iron motors IE3-EG series															
IE3 - EG 160 M	11	15	71.5	1470	91.4	91.3	90.3	20.4	7.7	0.85	2.2	2.3	0.0915	69	150
IE3 - EG 160 L	15	20	97.4	1470	92.1	92.0	90.6	27.3	7.8	0.86	2.2	2.3	0.1082	69	180
IE3 - EG 180 M	18.5	25	119.8	1475	92.6	92.5	91.2	33.5	7.8	0.86	2.0	2.3	0.2021	72	225
IE3 - EG 180 L	22	30	142.4	1475	93.0	92.9	91.7	39.7	7.8	0.86	2.0	2.3	0.2296	72	240
IE3 - EG 200 L	30	40	194.2	1475	93.6	93.5	92.4	53.8	7.3	0.86	2.0	2.3	0.3502	75	320
IE3 - EG 225 S	37	50	238.8	1480	93.9	93.8	92.7	66.1	7.4	0.86	2.0	2.3	0.5275	76	390
IE3 - EG 225 M	45	60	290.4	1480	94.2	94.1	93.1	80.2	7.4	0.86	2.0	2.3	0.6492	76	410
IE3 - EG 250 M	55	75	354.9	1480	94.6	94.5	94.0	97.6	7.4	0.86	2.2	2.3	1.0274	73	575
IE3 - EG 280 S	75	100	482.3	1485	95.0	94.9	94.0	129.0	6.9	0.88	2.0	2.3	1.6366	75	725
IE3 - EG 280 M	90	125	578.8	1485	95.2	95.1	94.5	155.0	6.9	0.88	2.0	2.3	1.9699	75	765
IE3 - EG 315 S	110	150	709.8	1480	95.4	95.3	94.4	189.0	7.0	0.88	2.0	2.2	3.2626	80	1060
IE3 - EG 315 M	132	180	851.8	1480	95.6	95.5	94.5	226.0	7.0	0.88	2.0	2.2	3.7126	80	1185
IE3 - EG 315 L1	160	220	1032.4	1480	95.8	95.7	95.0	271.0	7.1	0.89	2.0	2.2	4.6689	80	1270
IE3 - EG 315 L2	200	270	1290.5	1480	96.0	95.9	95.0	338.0	7.1	0.89	2.0	2.2	5.2876	80	1400
IE3 - EG 355 M	25	340	1602.3	1490	96.0	95.9	95.1	418.0	7.1	0.90	2.0	2.2	9.9342	80	on request
IE3 - EG 355 L1	315	430	2019.0	1490	96.0	95.9	95.1	526.0	7.1	0.90	2.0	2.2	12.609	80	on request
IE3 - EG 355 L2	355	480	2275.3	1490	96.0	95.9	95.1	607.0	7.0	0.88	1.7	2.2	13.660	80	on request

* Electrical data change depending on the series. For further information, please contact to Cosgra. MSE and EGQ data.

** Cast iron motors available for frame sizes 80 -132 (other powers and values on request).

ASYNCHRONOUS THREE-PHASE MOTORS

Squirrel-case rotor.
External cooling IC 411, continuous duty S1.
Insulation class 155 (F), protection degree IP55.

Aluminium motors **IE3-MS** series.
Cast iron motors **IE3-EG** series.

Synchronous speed 1000 rpm - 6 poles

400 V. 50 Hz

TYPE	Power		M _n N.m	n rpm	IE3 efficiency class EN 60034-2-1			I _n 400 V A	I _x /I _n	Cosφ	M _x /M _n	M _k /M _n	J Kg·m ²	Noise level dB(A)	m Kg		
	kW	hp			100%	75%	50%										
Aluminium motors IE3-MS series	IE3 - MS 90 S	-	0.75	1	7.83	910	78.9	79.1	74.8	1.90	6.5	0.72	2.2	2.2	0.004070	57	18.2
	IE3 - MS 90 L	-	1.1	1.5	11.36	920	81.0	81.3	78.4	2.70	6.5	0.73	2.2	2.2	0.005487	57	24.3
	IE3 - MS 100 L	-	1.5	2	15.24	935	82.5	82.5	82.7	3.47	6.5	0.76	2.0	2.0	0.009137	61	25.7
	IE3 - MS 112 M	-	2.2	3	22.23	940	84.3	84.3	84.5	5.00	6.5	0.76	2.0	2.0	0.017675	65	32.0
	IE3 - MS 132 S	-	3	4	30.00	940	85.6	85.6	85.8	6.70	6.5	0.76	2.0	2.0	0.033804	69	34.0
	IE3 - MS 132 M1	-	4	5.5	40.00	950	86.8	86.8	86.9	8.56	6.5	0.76	2.0	2.0	0.043946	69	45.0
	IE3 - MS 132 M2	-	5.5	7.5	55.00	950	88.0	88.0	88.2	11.80	7.5	0.77	2.0	2.0	0.053987	69	63.0
	IE3 - MS 160 M	-	7.5	10	75.00	950	89.1	89.1	89.4	15.85	7.5	0.77	2.0	2.0	0.109012	73	103.0
	IE3 - MS 160 L	-	11	15	110.00	950	90.3	90.5	89.3	22.40	7.5	0.79	2.0	2.0	0.154850	73	140.9
Cast iron motors IE3-EG series	IE3 - EG 160 M	-	7.5	10	73	975	89.1	89.0	87.2	15.6	7.0	0.78	2.0	2.1	0.1152	65	140
	IE3 - EG 160 L	-	11	15	108	975	90.3	90.2	88.6	22.3	7.2	0.79	2.0	2.1	0.1669	65	160
	IE3 - EG 180 L	-	15	20	147	975	91.2	91.1	89.6	29.3	7.3	0.81	2.0	2.1	0.2675	69	220
	IE3 - EG 200 L1	-	18.5	25	181	975	91.7	91.6	90.2	36.0	7.3	0.81	2.0	2.1	0.4027	72	260
	IE3 - EG 200 L2	-	22	30	215	975	92.2	92.1	90.8	42.0	7.4	0.82	2.0	2.1	0.4663	72	290
	IE3 - EG 225 M	-	30	40	292	980	92.9	92.8	91.6	57.5	6.9	0.81	2.0	2.1	0.7618	72	360
	IE3 - EG 250 M	-	37	50	361	980	93.3	93.2	92.3	68.1	7.1	0.84	2.0	2.1	1.3460	70	470
	IE3 - EG 280 S	-	45	60	439	980	93.7	93.6	92.5	80.6	7.3	0.86	2.0	2.0	1.8169	72	600
	IE3 - EG 280 M	-	55	75	536	980	94.1	94.0	93.3	98.1	7.3	0.86	2.0	2.0	2.0282	72	645
	IE3 - EG 315 S	-	75	100	723	990	94.6	94.5	93.6	135.0	6.6	0.85	2.0	2.0	3.7212	75	940
	IE3 - EG 315 M	-	90	125	868	990	94.9	94.8	93.7	163.0	6.7	0.84	2.0	2.0	4.3166	75	1040
	IE3 - EG 315 L1	-	110	150	1061	990	95.1	95.0	94.1	196.0	6.7	0.85	2.0	2.0	5.2097	75	1110
	IE3 - EG 315 L2	-	132	180	1273	990	95.4	95.3	94.5	232.0	6.8	0.86	2.0	2.0	6.1772	75	1115
	IE3 - EG 355 M1	-	160	220	1543	990	95.6	95.5	95.0	281.0	6.8	0.86	1.8	2.0	9.7679	79	on request
	IE3 - EG 355 M2	-	200	270	1929	990	95.8	95.7	95.0	346.0	6.8	0.87	1.8	2.0	12.059	79	on request
IE3 - EG 355 L	-	250	340	2412	990	95.8	95.7	95.0	433.0	6.8	0.87	1.8	2.0	14.953	79	on request	

* Electrical data change depending on the series. For further information, please contact to Cosgra. MSE and EGQ data.

ASYNCHRONOUS THREE-PHASE MOTORS

Squirrel-case rotor.
 External cooling IC 411, continuous duty S1.
 Insulation class 155 (F), protection degree IP55.

Aluminium motors **IE2-MS** series.
 Cast iron motors **IE2-EG** series.

Synchronous speed 3000 rpm - 2 poles

400 V. 50 Hz

TYPE	Power		M _n N.m	n rpm	IE2 efficiency class EN 60034-2-1			I _n 400 V A	I _x /I _n	Cosφ	M _x /M _n	M _k /M _n	J Kgm ²	Noise level dB(A)	m Kg		
	kW	hp			100%	75%	50%										
Aluminium motors IE2-MS series	IE2 - MS 80 1	-	0.75	1	2.58	2760	77.4	77.8	73.2	1.71	8.0	0.82	2.2	2.2	0.00085	67	9.50
	IE2 - MS 80 2	-	1.1	1.5	3.79	2760	79.6	80	77.1	2.40	8.0	0.83	2.2	2.2	0.00111	67	60.00
	• IE2 - MS 80 3	-	1.5	2	5.11	2790	81.3	81.6	80.6	3.22	8.0	0.83	2.2	2.2	0.00143	72	12.85
	IE2 - MS 90 S	-	1.5	2	5.05	2820	81.3	81.6	80.7	3.22	8.0	0.83	2.2	2.2	0.00143	72	17.60
	IE2 - MS 90 L	-	2.2	3	7.41	2820	83.2	83.5	82.5	4.49	8.0	0.85	2.2	2.2	0.00218	72	30.00
	• IE2 - MS 90 L2	-	3	4	10.07	2830	84.6	84.8	83.2	5.95	8.0	0.86	2.2	2.2	0.00290	76	19.55
	IE2 - MS 100 L	-	3	4	10.04	2840	84.6	84.8	83.6	5.95	8.5	0.86	2.2	2.0	0.00301	76	22.00
	• IE2 - MS 100 L	-	4	5.5	13.33	2850	85.8	86.0	84.2	7.82	8.5	0.86	2.2	2.0	0.00393	77	27.45
	IE2 - MS 112 M	-	4	5.5	13.33	2850	85.8	86.0	84.5	7.82	8.5	0.86	2.2	2.0	0.00627	77	28.20
	• IE2 - MS 112 L	-	5.5	7.5	18.27	2860	87.0	87.4	86.3	10.36	8.5	0.88	2.2	2.0	0.00782	80	31.15
	IE2 - MS 132 S1	-	5.5	7.5	18.27	2860	87.0	87.4	86.5	10.36	8.5	0.88	2.2	2.0	0.01202	80	42.30
	IE2 - MS 132 S2	-	7.5	10	24.48	2910	88.1	88.3	89.0	13.96	8.5	0.88	2.2	2.0	0.01464	80	47.75
	• IE2 - MS 132 M1	-	9.2	12.5	30.03	2910	88.1	88.3	87.7	17.08	8.5	0.88	2.2	2.0	0.01630	80	53.55
	• IE2 - MS 132 M2	-	11	15	35.67	2930	89.4	89.7	88.5	19.73	8.5	0.90	2.2	2.0	0.01944	86	59.55
	IE2 - MS 160 M1	-	11	15	35.67	2930	89.4	89.7	88.9	19.73	8.5	0.90	2.2	2.0	0.04847	86	82.00
	IE2 - MS 160 M2	-	15	20	48.47	2940	90.3	90.5	89.9	26.34	8.5	0.91	2.2	2.0	0.05942	86	94.50
	IE2 - MS 160 L	-	18.5	25	59.78	2940	90.9	91.0	90.1	32.28	8.5	0.91	2.2	2.0	0.06881	86	105.00
	Cast iron motors IE2-EG series	IE2 - EG 160 M1	-	11	15	35.85	2930	89.4	89.3	87.8	19.9	8.1	0.89	2.2	2.3	0.0489	81
IE2 - EG 160 M2		-	15	20	48.89	2930	90.3	90.2	88.8	26.9	8.1	0.89	2.2	2.3	0.0559	81	132
IE2 - EG 160 L		-	18.5	25	60.30	2930	90.9	90.8	89.5	33.0	8.1	0.89	2.2	2.3	0.0648	81	151
IE2 - EG 180 M		-	22	30	71.46	2940	91.3	91.2	89.9	38.6	8.1	0.88	2.0	2.3	0.0808	83	203
IE2 - EG 200 L1		-	30	40	97.12	2950	92.0	91.9	90.7	52.3	8.1	0.88	2.0	2.3	0.1630	84	246
IE2 - EG 200 L2		-	37	50	119.80	2950	92.5	92.4	91.3	64.1	8.1	0.89	2.0	2.3	0.1720	84	256
IE2 - EG 225 M		-	45	60	145.20	2960	92.9	92.8	91.8	77.7	8.1	0.89	2.0	2.3	0.3020	86	328
IE2 - EG 250 M		-	55	75	177.20	2965	93.2	93.1	92.1	94.6	8.1	0.90	2.0	2.3	0.4200	89	433
IE2 - EG 280 S		-	75	100	242.00	2960	93.8	93.7	92.8	128.0	8.1	0.90	2.0	2.3	0.9860	91	572
IE2 - EG 280 M		-	90	125	290.40	2960	94.1	94.0	93.1	151.0	8.1	0.91	2.0	2.3	1.0400	91	632
IE2 - EG 315 S		-	110	150	353.10	2975	94.3	94.2	93.4	185.0	7.7	0.90	1.8	2.2	1.3300	92	950
IE2 - EG 315 M		-	132	180	423.70	2975	94.6	94.5	93.7	221.0	7.7	0.90	1.8	2.2	1.5000	92	1080
IE2 - EG 315 L1		-	160	220	513.60	2975	94.8	94.8	93.9	264.0	7.7	0.89	1.8	2.2	1.6700	92	1210
IE2 - EG 315 L2		-	200	270	642.00	2975	95.0	95.0	94.2	330.0	7.7	0.89	1.8	2.2	1.8800	92	1240
IE2 - EG 355 M		-	250	340	801.00	2980	95.0	95.0	94.2	412.0	7.7	0.92	1.6	2.2	4.0200	100	1970
IE2 - EG 355 L1	-	315	430	1009.00	2980	95.0	95.0	94.2	520.0	7.7	0.92	1.6	2.2	4.8600	100	2000	

• Increased power.

* Electrical data change depending on the series. For further information, please contact to Cosgra. MSE and EGQ data.

ASYNCHRONOUS THREE-PHASE MOTORS

Squirrel-case rotor.
External cooling IC 411, continuous duty S1.
Insulation class 155 (F), protection degree IP55.

Aluminium motors **IE2-MS** series.
Cast iron motors **IE2-EG** series.

Synchronous speed 1500 rpm - 4 poles

400 V. 50 Hz

	TYPE	Power		M _N N.m	n rpm	IE2 efficiency class EN 60034-2-1			I _N 400 V A	I _x /I _N	Cosφ	M _x /M _N	M _k /M _N	J Kgm ²	Noise level dB(A)	m Kg	
		kW	hp			100%	75%	50%									
Aluminium motors IE2-MS series	IE2 - MS 80 2	-	0.75	1	5.16	1380	79.6	80.0	76.6	1.74	8.0	0.78	2.2	2.2	0.00206	58	9.80
	IE2 - MS 80 3	-	1.1	1.5	7.52	1390	81.4	81.7	79.2	2.50	8.0	0.78	2.2	2.2	0.00287	61	18.25
	IE2 - MS 90 S	-	1.1	1.5	7.52	1390	81.4	81.7	80.1	2.50	8.0	0.79	2.2	2.2	0.00287	61	14.50
	IE2 - MS 90 L	-	1.5	2	10.18	1400	82.8	81.8	81.0	3.26	8.0	0.80	2.2	2.2	0.00371	61	15.40
	• IE2 - MS 90 L2	-	2.2	3	14.82	1410	84.3	84.7	81.8	4.70	8.5	0.80	2.2	2.2	0.00731	64	22.85
	IE2 - MS 100 L1	-	2.2	3	14.80	1410	84.3	83.5	82.5	4.70	8.5	0.80	2.2	2.2	0.00731	64	22.00
	IE2 - MS 100 L2	-	3	4	20.10	1420	85.5	85.7	84.0	6.25	8.5	0.81	2.2	2.2	0.00905	64	26.00
	• IE2 - MS 100 L3	-	4	5.5	26.57	1430	86.6	86.9	85.1	8.13	8.5	0.82	2.2	2.2	0.01331	65	29.15
	IE2 - MS 112 M	-	4	5.5	26.60	1430	86.6	86.9	85.9	8.13	8.5	0.82	2.2	2.2	0.01331	65	32.70
	• IE2 - MS 112 L	-	5.5	7.5	36.28	1440	87.7	87.9	86.9	10.90	8.5	0.83	2.2	2.2	0.02774	71	40.35
	IE2 - MS 132 S	-	5.5	7.5	36.30	1440	87.7	87.9	86.8	10.90	8.5	0.83	2.2	2.2	0.02774	71	44.00
	IE2 - MS 132 M	-	7.5	10	49.10	1450	88.7	88.9	88.1	14.52	8.5	0.84	2.2	2.2	0.03586	71	54.60
	• IE2 - MS 132 L1	-	9.2	12.5	60.28	1450	88.7	88.9	88.8	17.82	8.5	0.84	2.2	2.2	0.04195	72	60.55
	• IE2 - MS 132 L2	-	11	15	71.58	1460	89.8	90.0	89.0	21.04	8.5	0.84	2.2	2.2	0.08963	75	60.50
	IE2 - MS 160 M	-	11	15	71.58	1460	89.8	90.0	90.7	21.04	8.5	0.86	2.2	2.2	0.08963	75	94.50
	IE2 - MS 160 L	-	15	20	97.60	1460	90.6	90.8	90.7	27.46	8.5	0.87	2.2	2.2	0.11835	75	102.40
Cast iron motors IE2-EG series	IE2 - EG 160 M	-	11	15	72.0	1460	89.8	89.7	88.2	21.0	8.9	0.84	2.2	2.3	0.0771	73	123
	IE2 - EG 160 L	-	15	20	98.1	1460	90.6	90.5	89.1	28.1	8.9	0.85	2.2	2.3	0.1010	73	153
	IE2 - EG 180 M	-	18.5	25	120.0	1470	91.2	91.1	89.8	34.0	7.9	0.86	2.2	2.3	0.1520	76	204
	IE2 - EG 180 L	-	22	30	143.0	1470	91.6	91.5	90.3	40.3	7.9	0.86	2.2	2.3	0.1870	76	215
	IE2 - EG 200 L	-	30	40	195.0	1470	92.3	92.2	91.1	54.5	7.9	0.86	2.2	2.3	0.2850	76	243
	IE2 - EG 225 S	-	37	50	240.0	1475	92.7	92.6	91.5	66.2	7.9	0.87	2.2	2.3	0.4730	78	305
	IE2 - EG 225 M	-	45	60	292.0	1470	93.1	93.0	92.0	80.1	7.9	0.87	2.2	2.3	0.5540	78	328
	IE2 - EG 250 M	-	55	75	355.0	1480	93.5	93.4	92.4	97.5	7.9	0.87	2.2	2.3	0.7510	79	452
	IE2 - EG 280 S	-	75	100	486.0	1475	94.0	93.9	93.0	132.0	7.9	0.87	2.2	2.3	1.9200	80	592
	IE2 - EG 280 M	-	90	125	583.0	1475	94.2	94.1	93.3	158.0	7.9	0.87	2.2	2.3	2.3200	80	672
	IE2 - EG 315 S	-	110	150	707.0	1485	94.5	94.4	93.6	195.0	7.6	0.86	2.1	2.2	2.3400	88	980
	IE2 - EG 315 M	-	132	180	849.0	1485	94.7	94.6	93.8	233.0	7.6	0.86	2.1	2.2	2.5800	88	1040
	IE2 - EG 315 L1	-	160	220	1029.0	1485	94.9	94.9	94.1	282.0	7.6	0.86	2.1	2.2	2.9600	88	1180
	IE2 - EG 315 L2	-	200	270	1286.0	1485	95.1	95.1	94.3	357.0	7.6	0.85	2.1	2.2	3.4600	88	1260
	IE2 - EG 355 M	-	250	340	1608.0	1485	95.1	95.1	94.3	421.0	7.6	0.90	2.1	2.2	6.6000	95	1810
IE2 - EG 355 L2	-	315	430	2026.0	1485	95.1	95.1	94.3	537.0	7.6	0.89	2.1	2.2	7.5500	95	1910	

• Increased power.

* Electrical data change depending on the series. For further information, please contact to Cosgra. MSE and EGQ data.

ASYNCHRONOUS THREE-PHASE MOTORS

Squirrel-case rotor.
 External cooling IC 411, continuous duty S1.
 Insulation class 155 (F), protection degree IP55.

Aluminium motors **IE2-MS** series.
 Cast iron motors **IE2-EG** series.

Synchronous speed 1000 rpm - 6 poles

400 V. 50 Hz

TYPE	Power		M _n N.m	n rpm	IE2 efficiency class EN 60034-2-1			I _n 400 V A	I _x /I _n	Cosφ	M _x /M _n	M _r /M _n	J Kgm ²	Noise level dB(A)	m Kg		
	kW	hp			100%	75%	50%										
Aluminium motors IE2-MS series	IE2 - MS 90 S	-	0.75	1	7.92	900	75.9	76.2	74.2	1.98	7.5	0.72	2.2	2.2	0.00336	57	13.80
	IE2 - MS 90 L	-	1.1	1.5	11.36	920	78.1	78.5	75.3	2.78	7.5	0.73	2.2	2.2	0.00480	57	17.05
	IE2 - MS 100 L	-	1.5	2	15.24	935	79.8	80.0	71.9	3.56	7.5	0.76	2.2	2.0	0.00955	61	22.65
	IE2 - MS 112 M	-	2.2	3	22.23	940	81.8	82.0	81.9	5.10	7.5	0.76	2.2	2.0	0.01697	65	27.20
	IE2 - MS 132 S	-	3	4	30.32	940	83.3	83.6	82.8	6.83	7.5	0.76	2.2	2.0	0.02993	69	35.55
	IE2 - MS 132 M1	-	4	5.5	40.00	950	84.6	84.7	83.7	8.97	7.5	0.76	2.2	2.0	0.04026	69	45.15
	IE2 - MS 132 M2	-	5.5	7.5	55.00	950	86.0	86.4	85.0	11.98	7.5	0.77	2.2	2.0	0.05341	69	56.00
	• IE2 - MS 132 L	-	7.5	10	75.00	950	87.2	87.5	86.0	16.12	7.5	0.77	2.2	2.0	0.08969	73	58.00
	IE2 - MS 160 M	-	7.5	10	75.00	950	87.2	87.5	86.0	16.12	7.5	0.77	2.2	2.0	0.08969	73	74.00
	IE2 - MS 160 L	-	11	15	110.0	950	88.7	88.9	87.2	22.65	7.5	0.79	2.2	2.0	0.12273	73	92.00
Cast iron motors IE2-EG series	IE2 - EG 160 M	-	7.5	10	73.8	970	87.2	87.1	85.3	16.1	6.0	0.77	2.0	2.1	0.0964	73	151
	IE2 - EG 160 L	-	11	15	108.0	970	88.7	88.6	87.0	22.9	6.0	0.78	2.0	2.1	0.1270	73	167
	IE2 - EG 180 L	-	15	20	148.0	970	89.7	89.6	88.1	29.7	7.5	0.81	2.0	2.1	0.2010	73	206
	IE2 - EG 200 L1	-	18.5	25	182.0	970	90.4	90.3	88.9	36.4	7.5	0.81	2.1	2.1	0.3250	73	243
	IE2 - EG 200 L2	-	22	30	217.0	970	90.9	90.8	89.5	42.0	7.5	0.83	2.1	2.1	0.3710	73	256
	IE2 - EG 225 M	-	30	40	292.0	980	91.7	91.6	90.4	56.2	7.5	0.84	2.0	2.1	0.5330	74	317
	IE2 - EG 250 M	-	37	50	361.0	980	92.2	92.1	91.0	67.3	7.5	0.86	2.1	2.1	0.8770	76	435
	IE2 - EG 280 S	-	45	60	439.0	980	92.7	92.6	91.5	81.4	7.5	0.86	2.1	2.0	1.8500	78	603
	IE2 - EG 280 M	-	55	75	536.0	980	93.1	93.0	92.0	99.1	7.5	0.86	2.1	2.0	2.1200	78	693
	IE2 - EG 315 S	-	75	100	727.0	985	93.7	93.6	92.7	135.0	7.5	0.85	2.0	2.0	2.6100	83	970
	IE2 - EG 315 M	-	90	125	873.0	985	94.0	93.9	93.0	162.0	7.5	0.85	2.0	2.0	3.0400	83	1180
	IE2 - EG 315 L1	-	110	150	1066.0	985	94.3	94.2	93.4	195.0	7.3	0.86	2.0	2.0	3.7100	83	1240
	IE2 - EG 315 L2	-	132	180	1280.0	985	94.6	94.5	93.7	234.0	7.3	0.86	2.0	2.0	4.2400	83	1300
IE2 - EG 355 M1	-	160	220	1543.0	990	94.8	94.8	93.9	276.0	7.3	0.88	1.9	2.0	7.4400	85	1740	

• Increased power.

* Electrical data change depending on the series. For further information, please contact to Cosgra. MSE and EGQ data.

ASYNCHRONOUS THREE-PHASE MOTORS

Squirrel-case rotor.
External cooling IC 411, continuous duty S1.
Insulation class 155 (F), protection degree IP55.

Aluminium motors **IE1-MS** series.
Cast iron motors **IE1-EG** series.

Synchronous speed 3000 rpm - 2 poles

400 V. 50 Hz

	TYPE	Power		M _n N.m	n rpm	IE1 efficiency class EN 60034-2-1 100%	I _n 400 V A	I _s /I _n	Cosφ	M _s /M _n	M _r /M _n	J Kgm ²	Noise level dB(A)	m Kg	
		kW	hp												
Aluminium motors IE1-MS series (**)	MS 56 1	-	0.09	0.12	0.32	2660	56.0	0.35	6.0	0.65	2.2	2.2	0.00006	58	2.6
	MS 56 2	-	0.12	0.17	0.42	2690	58.0	0.52	6.0	0.68	2.2	2.2	0.00008	58	3.0
	• MS 56 3	-	0.18	0.25	0.63	2710	60.0	0.60	6.0	0.72	2.2	2.2	0.00010	61	4.0
	MS 63 1	-	0.18	0.25	0.63	2710	60.0	0.60	6.0	0.72	2.2	2.2	0.00013	61	4.0
	MS 63 2	-	0.25	0.33	0.88	2710	61.0	0.76	6.0	0.78	2.2	2.2	0.00015	61	4.2
	• MS 63 3	-	0.37	0.5	1.30	2710	64.0	1.10	6.0	0.78	2.2	2.2	0.00017	62	4.7
	MS 71 1	-	0.37	0.5	1.29	2730	71.0	1.10	6.0	0.78	2.2	2.2	0.00021	64	5.2
	MS 71 2	-	0.55	0.75	1.89	2760	72.0	1.73	6.0	0.79	2.2	2.2	0.00027	64	6.0
	• MS 71 3	-	0.75	1	2.61	2730	77.0	1.72	6.0	0.82	2.2	2.2	0.00033	65	7.0
	IE1 - MS 80 1	-	0.75	1	2.58	2760	77.0	1.72	6.0	0.82	2.2	2.2	0.00039	67	8.7
	IE1 - MS 80 2	-	1.1	1.5	3.79	2760	78.5	2.45	6.0	0.83	2.2	2.2	0.00051	67	10.0
	• IE1 - MS 80 3	-	1.5	2	5.11	2790	81.0	3.23	6.0	0.83	2.2	2.2	0.00068	70	11.2
	IE1 - MS 90 S	-	1.5	2	5.05	2820	81.0	3.23	6.0	0.83	2.2	2.2	0.00093	72	12.0
	IE1 - MS 90 L1	-	2.2	3	7.41	2820	81.5	4.60	6.0	0.85	2.2	2.2	0.00115	72	14.5
	• IE1 - MS 90 L2	-	3	4	10.07	2830	83.0	6.10	6.0	0.86	2.2	2.2	0.00142	74	15.0
	IE1 - MS 100 L1	-	3	4	10.04	2840	83.0	6.10	7.0	0.86	2.0	2.0	0.00211	76	20.0
	• IE1 - MS 100 L2	-	4	5.5	13.33	2850	84.5	7.98	7.0	0.86	2.0	2.0	0.00272	77	24.0
	IE1 - MS 112 M	-	4	5.5	13.33	2850	84.5	7.98	7.0	0.87	2.0	2.0	0.00317	77	26.0
	• IE1 - MS 112 L	-	5.5	7.5	18.27	2860	86.0	10.55	7.0	0.88	2.0	2.0	0.00434	78	29.3
	IE1 - MS 132 S1	-	5.5	7.5	18.27	2860	86.0	10.55	7.0	0.88	2.0	2.0	0.00744	80	38.4
IE1 - MS 132 S2	-	7.5	10	24.48	2910	87.5	14.12	7.5	0.88	2.0	2.0	0.00910	80	41.3	
• IE1 - MS 132 M1	-	9.2	12.5	30.03	2910	87.5	17.32	7.5	0.88	2.0	2.0	0.01072	81	48.2	
• IE1 - MS 132 M2	-	11	15	35.67	2930	87.5	20.48	7.5	0.90	2.0	2.0	0.01146	83	52.5	
IE1 - MS 160 M1	-	11	15	35.67	2930	87.5	20.48	7.5	0.90	2.0	2.0	0.02380	86	76.0	
IE1 - MS 160 M2	-	15	20	48.47	2940	88.5	27.00	7.5	0.91	2.0	2.0	0.03117	86	77.5	
IE1 - MS 160 L	-	18.5	25	59.78	2940	89.5	33.00	7.5	0.91	2.0	2.0	0.03617	86	92.0	
Cast iron motors IE1-EG series	IE1 - EG 160 M1	-	11	15	35.9	2930	88.4	21.2	7.5	0.89	2.2	2.3	0.0377	88	109
	IE1 - EG 160 M2	-	15	20	48.9	2930	89.4	28.6	7.5	0.89	2.2	2.3	0.0449	88	125
	IE1 - EG 160 L	-	18.5	25	60.3	2930	90.0	34.7	7.5	0.90	2.2	2.3	0.0550	88	147
	IE1 - EG 180 M	-	22	30	71.5	2940	90.5	41.0	7.5	0.90	2.0	2.3	0.0750	91	180
	IE1 - EG 200 L1	-	30	40	97.1	2950	91.4	55.4	7.5	0.90	2.0	2.3	0.1240	94	240
	IE1 - EG 200 L2	-	37	50	120.0	2950	92.0	67.9	7.5	0.90	2.0	2.3	0.1390	94	255
	IE1 - EG 225 M	-	45	60	145.0	2970	92.5	82.1	7.5	0.90	2.0	2.3	0.2330	94	309
	IE1 - EG 250 M	-	55	75	177.0	2970	93.0	99.8	7.5	0.90	2.0	2.3	0.3120	95	403
	IE1 - EG 280 S	-	75	100	241.0	2970	93.6	135.0	7.5	0.90	2.0	2.3	0.5790	96	572
	IE1 - EG 280 M	-	90	125	289.0	2970	93.9	160.0	7.5	0.91	2.0	2.3	0.6750	96	620
	IE1 - EG 315 S	-	110	150	353.0	2980	94.0	195.0	7.1	0.91	1.8	2.2	1.1800	98	980
	IE1 - EG 315 M	-	132	180	423.0	2980	94.5	233.0	7.1	0.91	1.8	2.2	1.8200	98	1080
IE1 - EG 315 L1	-	160	220	513.0	2980	94.6	279.0	7.1	0.92	1.8	2.2	2.0800	101	1160	
IE1 - EG 315 L2	-	200	270	641.0	2980	94.8	348.0	7.1	0.92	1.8	2.2	2.4100	101	1190	

• Increased power.

* Electrical data change depending on the series. For further information, please contact to Cosgra. MSE and EGQ data.

** Cast iron motors available for frame sizes 80 -132 (other powers and values on request).

ASYNCHRONOUS THREE-PHASE MOTORS

Squirrel-case rotor.
 External cooling IC 411, continuous duty S1.
 Insulation class 155 (F), protection degree IP55.

Aluminium motors **IE1-MS** series.
 Cast iron motors **IE1-EG** series.

Synchronous speed 1500 rpm - 4 poles

400 V, 50 Hz

	TYPE	Power		M_n N.m	n rpm	IE1 efficiency class EN 60034-2-1 100%	I_n 400 V A	I_x/I_n	Cosφ	M_x/M_n	M_k/M_n	J Kgm ²	Noise level dB(A)	m Kg
		kW	hp											
Aluminium motors IE1-MS series (**)	MS 56 1	- 0.06	0.08	0.43	1320	49.0	0.30	6.0	0.59	2.2	2.2	0.00009	50	2.9
	MS 56 2	- 0.09	0.12	0.65	1320	51.0	0.42	6.0	0.61	2.2	2.2	0.00011	50	3.2
	• MS 56 3	- 0.12	0.17	0.86	1320	53.0	0.52	6.0	0.63	2.2	2.2	0.00014	52	3.7
	MS 63 1	- 0.12	0.17	0.86	1320	53.0	0.52	6.0	0.63	2.2	2.2	0.00016	52	3.7
	MS 63 2	- 0.18	0.25	1.27	1350	60.0	0.67	6.0	0.65	2.2	2.2	0.00020	52	4.2
	• MS 63 3	- 0.25	0.33	1.76	1350	61.0	0.90	6.0	0.66	2.2	2.2	0.00023	54	5.0
	MS 71 1	- 0.25	0.33	1.76	1350	61.0	0.90	6.0	0.66	2.2	2.2	0.00058	55	5.0
	MS 71 2	- 0.37	0.5	2.57	1370	66.0	1.12	6.0	0.73	2.2	2.2	0.00065	55	5.8
	• MS 71 3	- 0.55	0.75	3.79	1380	67.0	1.60	6.0	0.75	2.2	2.2	0.00087	57	6.5
	MS 80 1	- 0.55	0.75	3.79	1380	67.0	1.60	6.0	0.75	2.2	2.2	0.00124	58	8.1
	IE1 - MS 80 2	- 0.75	1	5.16	1380	78.0	1.79	6.0	0.78	2.2	2.2	0.00167	58	9.1
	• IE1 - MS 80 3	- 1.1	1.5	7.52	1390	79.0	2.60	6.0	0.78	2.2	2.2	0.00185	60	11.0
	IE1 - MS 90 S	- 1.1	1.5	7.52	1390	79.0	2.55	6.0	0.79	2.2	2.2	0.00168	61	11.7
	IE1 - MS 90 L1	- 1.5	2	10.18	1400	81.5	3.35	6.0	0.80	2.2	2.2	0.00217	61	14.4
	• IE1 - MS 90 L2	- 2.2	3	14.82	1410	83.0	4.80	7.0	0.80	2.2	2.2	0.00262	63	17.6
	IE1 - MS 100 L1	- 2.2	3	14.82	1410	83.0	4.80	7.0	0.80	2.2	2.2	0.00335	64	19.2
	IE1 - MS 100 L2	- 3	4	20.07	1420	84.5	6.35	7.0	0.81	2.2	2.2	0.00463	64	22.5
	• IE1 - MS 100 L3	- 4	5.5	26.57	1430	85.0	8.32	7.0	0.82	2.2	2.2	0.00508	65	27.3
	IE1 - MS 112 M	- 4	5.5	26.57	1430	85.0	8.32	7.0	0.82	2.2	2.2	0.00866	65	29.0
	• IE1 - MS 112 L	- 5.5	7.5	36.28	1440	87.0	11.0	7.5	0.83	2.2	2.2	0.00955	68	35.7
	IE1 - MS 132 S	- 5.5	7.5	36.28	1440	87.0	11.0	7.5	0.83	2.2	2.2	0.01803	71	39.0
	IE1 - MS 132 M	- 7.5	10	49.14	1450	87.5	15.0	7.5	0.85	2.2	2.2	0.02218	71	48.6
	• IE1 - MS 132 L1	- 9.2	12.5	60.28	1450	87.5	18.0	7.5	0.85	2.2	2.2	0.02436	74	56.5
	• IE1 - MS 132 L2	- 11	15	71.58	1460	88.5	20.0	7.5	0.86	2.2	2.2	0.02672	74	64.0
	IE1 - MS 160 M	- 11	15	71.58	1460	88.5	20.0	7.5	0.86	2.2	2.2	0.04575	75	73.0
IE1 - MS 160 L	- 15	20	97.60	1460	89.5	28.0	7.5	0.87	2.2	2.2	0.05968	75	88.5	
Cast iron motors IE1-EG series	IE1 - EG 160 M	- 11	15	72.0	1460	88.4	22.5	7.0	0.84	2.2	2.3	0.0747	80	118
	IE1 - EG 160 L	- 15	20	98.1	1460	89.4	30.0	7.5	0.85	2.2	2.3	0.0918	79	138
	IE1 - EG 180 M	- 18.5	25	120.2	1470	90.0	36.3	7.5	0.86	2.2	2.3	0.1390	80	182
	IE1 - EG 180 L	- 22	30	142.9	1470	90.5	43.0	7.5	0.86	2.2	2.3	0.1580	80	190
	IE1 - EG 200 L	- 30	40	194.9	1470	91.4	58.0	7.2	0.86	2.2	2.3	0.2620	83	243
	IE1 - EG 225 S	- 37	50	239.0	1480	92.0	70.2	7.2	0.87	2.2	2.3	0.4060	85	284
	IE1 - EG 225 M	- 45	60	290.0	1480	92.5	85.0	7.2	0.87	2.2	2.3	0.4690	84	320
	IE1 - EG 250 M	- 55	75	355.0	1480	93.0	103	7.2	0.87	2.2	2.3	0.6600	86	452
	IE1 - EG 280 S	- 75	100	484.0	1480	93.6	140	7.2	0.87	2.2	2.3	1.1200	89	562
	IE1 - EG 280 M	- 90	125	577.0	1490	93.9	167	7.2	0.87	2.2	2.3	1.4600	89	667
	IE1 - EG 315 S	- 110	150	705.0	1490	94.5	201	6.9	0.88	2.1	2.2	3.1100	96	1000
	IE1 - EG 315 M	- 132	180	846.0	1490	94.8	240	6.9	0.88	2.1	2.2	3.6200	96	1100
	IE1 - EG 315 L1	- 160	220	1026.0	1490	94.9	288	6.9	0.89	2.1	2.2	4.1300	100	1160
	IE1 - EG 315 L2	- 200	270	1282.0	1490	94.9	360	6.9	0.89	2.1	2.2	4.9400	100	1270
	IE1 - EG 355 M	- 250	340	1608.0	1485	95.2	443	6.9	0.90	2.1	2.2	5.6700	104	1700
IE1 - EG 355 L2	- 315	430	2026.0	1485	95.2	559	6.9	0.90	2.1	2.2	6.6600	104	1850	

• Increased power.

* Electrical data change depending on the series. For further information, please contact to Cosgra. MSE and EGQ data.

** Cast iron motors available for frame sizes 80 -132 (other powers and values on request).



ASYNCHRONOUS THREE-PHASE MOTORS

Squirrel-case rotor.
External cooling IC 411, continuous duty S1.
Insulation class 155 (F), protection degree IP55.

Aluminium motors **IE1-MS** series.
Cast iron motors **IE1-EG** series.

Synchronous speed 1000 rpm - 6 poles

400 V. 50 Hz

	TYPE	Power		M _N N.m	n rpm	IE1 efficiency class EN 60034-2-1		I _N 400 V A	I _x /I _N	Cosφ	M _x /M _N	M _k /M _N	J Kg·m ²	Noise level dB(A)	m Kg
		kW	hp			100%									
Aluminium motors IE1-MS series	MS 63 1	- 0.09	0.12	1.0	840	41.0	0.53	5.0	0.60	2.2	2.2	0.00021	50	4.2	
	MS 63 2	- 0.12	0.17	1.4	840	44.0	0.65	5.0	0.61	2.2	2.2	0.00023	50	4.5	
	MS 71 1	- 0.18	0.25	2.0	860	56.0	0.71	5.0	0.66	2.2	2.2	0.00065	52	5.6	
	MS 71 2	- 0.25	0.33	2.8	860	59.0	0.89	5.0	0.69	2.2	2.2	0.00087	52	6.0	
	• MS 71 3	- 0.37	0.5	4.0	875	63.0	1.22	5.0	0.70	2.2	2.2	0.00108	54	6.8	
	MS 80 1	- 0.37	0.5	3.9	890	63.0	1.21	5.0	0.70	2.2	2.2	0.00140	56	8.1	
	MS 80 2	- 0.55	0.75	5.8	900	68.0	1.63	5.0	0.72	2.2	2.2	0.00186	56	9.6	
	• IE1 - MS 80 3	- 0.75	1	7.9	900	73.0	2.10	5.0	0.72	2.2	2.2	0.00232	58	10.0	
	IE1 - MS 90 S	- 0.75	1	9.8	920	73.0	2.62	5.0	0.72	2.2	2.2	0.00266	59	11.3	
	IE1 - MS 90 L1	- 1.1	1.5	11.4	920	75.0	2.92	6.0	0.73	2.2	2.2	0.00350	59	14.4	
	• IE1 - MS 90 L2	- 1.5	2	15.2	945	75.0	3.80	6.0	0.76	2.2	2.2	0.00625	60	15.5	
	IE1 - MS 100 L1	- 1.5	2	15.2	935	77.0	3.72	6.0	0.76	2.0	2.0	0.00562	61	18.8	
	• IE1 - MS 100 L2	- 2.2	3	22.0	955	78.0	5.40	6.0	0.76	2.2	2.2	0.01225	63	19.8	
	IE1 - MS 112 M	- 2.2	3	22.2	940	78.5	5.35	6.0	0.76	2.0	2.0	0.01333	64	25.0	
	• IE1 - MS 112 L	- 3	4	29.8	960	80.0	7.10	6.5	0.76	2.0	2.0	0.01800	64	30.0	
	IE1 - MS 132 S	- 3	4	30.3	940	80.0	7.15	6.0	0.76	2.0	2.0	0.02187	64	35.0	
	IE1 - MS 132 M1	- 4	5.5	40.0	950	83.0	9.20	6.0	0.76	2.0	2.0	0.02541	68	47.6	
	IE1 - MS 132 M2	- 5.5	7.5	55.0	950	85.0	12.20	6.0	0.77	2.0	2.0	0.03068	68	50.7	
	• IE1 - MS 132 L	- 7.5	10	75.0	950	86.0	16.60	6.5	0.77	2.0	2.0	0.03602	68	47.6	
	IE1 - MS 160 M	- 7.5	10	75.0	950	86.0	16.60	6.5	0.77	2.0	2.0	0.06927	68	70.0	
IE1 - MS 160 L	- 11	15	110.0	950	89.0	22.70	7.0	0.79	2.0	2.0	0.12674	73	87.0		
Cast iron motors IE1-EG series	IE1 - EG 160 M	- 7.5	10	73.8	970	86.0	17.0	6.5	0.77	2.0	2.1	0.0881	80	119	
	IE1 - EG 160 L	- 11	15	108	970	87.5	24.5	6.5	0.78	2.0	2.1	0.1160	80	147	
	IE1 - EG 180 L	- 15	20	148	970	89.0	31.6	7.0	0.81	2.0	2.1	0.2070	79	195	
	IE1 - EG 200 L1	- 18.5	25	182	970	90.0	38.6	7.0	0.81	2.1	2.1	0.3150	82	220	
	IE1 - EG 200 L2	- 22	30	217	970	90.0	44.7	7.0	0.83	2.1	2.1	0.3600	82	250	
	IE1 - EG 225 M	- 30	40	292	980	91.5	59.3	7.0	0.84	2.0	2.1	0.5470	82	292	
	IE1 - EG 250 M	- 37	50	361	980	92.0	71.0	7.0	0.86	2.1	2.1	0.8340	84	408	
	IE1 - EG 280 S	- 45	60	439	980	92.5	86.0	7.0	0.86	2.1	2.0	1.3900	85	536	
	IE1 - EG 280 M	- 55	75	536	980	92.8	105.0	7.0	0.86	2.1	2.0	1.6500	85	595	
	IE1 - EG 315 S	- 75	100	723	990	93.5	142.0	7.0	0.86	2.0	2.0	4.1100	90	990	
	IE1 - EG 315 M	- 90	125	868	990	93.8	170.0	7.0	0.86	2.0	2.0	4.2800	90	1080	
	IE1 - EG 315 L1	- 110	150	1061	990	94.0	207.0	6.7	0.86	2.0	2.0	5.4500	90	1150	
	IE1 - EG 315 L2	- 132	180	1273	990	94.2	245.0	6.7	0.87	2.0	2.0	6.1200	89	1210	
IE1 - EG 355 M1	- 160	220	1543	990	94.5	292.0	6.7	0.88	1.9	2.0	8.8500	96	1600		

• Increased power.

* Electrical data change depending on the series. For further information, please contact to Cosgra. MSE and EGQ series.

ASYNCHRONOUS THREE-PHASE MOTORS

Squirrel-case rotor.
 External cooling IC 411, continuous duty S1
 Insulation class 155 (F), protection degree IP55.

Aluminium motors **IE1-MS** series.
 Cast iron motors **IE1-EG** series.

Synchronous speed 750 rpm - 8 poles

400 V. 50 Hz

TYPE	Power		M _n N.m	n rpm	IE1 eff. class EN 60034-2 100%	I _n 400 V A	I _s /I _n	Cosφ	M _x /M _n	M _r /M _n	J Kgm ²	Noise level dB(A)	m Kg		
	kW	hp													
Aluminium motors IE1-MS series	MS 71 1	-	0.09	0.12	1.4	590	48	0.48	4.0	0.56	1.8	1.8	0.00084	50	5.6
	MS 71 2	-	0.12	0.17	1.9	595	49	0.58	4.0	0.57	1.8	1.8	0.00087	50	6.0
	MS 80 1	-	0.18	0.25	2.8	610	52	0.84	4.0	0.60	1.8	1.8	0.00140	52	9.4
	MS 80 2	-	0.25	0.33	3.8	620	55	1.08	4.0	0.61	1.8	1.8	0.00186	52	10.1
	• MS 80 3	-	0.37	0.5	5.3	660	63	1.40	4.0	0.61	1.8	1.8	0.00195	56	14.8
	MS 90 S	-	0.37	0.5	5.3	660	63	1.40	4.0	0.61	1.8	1.8	0.00186	56	12.5
	MS 90 L	-	0.55	0.75	7.9	660	63	2.07	5.0	0.61	1.8	1.8	0.00217	56	15.3
	MS 100 L1	-	0.75	1	10.3	690	71	2.36	5.0	0.65	1.8	1.8	0.00563	59	17.2
	MS 100 L2	-	1.1	1.5	15.1	690	73	3.22	5.0	0.68	1.8	1.8	0.00716	59	19.5
	MS 112 M	-	1.5	2	20.7	690	75	4.20	6.0	0.69	1.8	1.8	0.01159	61	25.5
	MS 132 S	-	2.2	3	29.4	710	78	5.78	6.5	0.71	1.8	1.8	0.02541	64	34.2
	MS 132 M	-	3	4	40.1	710	79	7.50	6.5	0.73	1.8	1.8	0.03068	64	40.0
	MS 160 M1	-	4	5.5	52.8	720	81	9.80	7.0	0.73	1.8	1.8	0.06927	68	59.0
	MS 160 M2	-	5.5	7.5	72.6	720	83	13.00	7.0	0.74	1.8	1.8	0.09353	68	69.0
	MS 160 L	-	7.5	10	99.0	720	83	17.50	7.0	0.75	1.8	1.8	0.11300	68	87.0
Cast iron motors IE1-EG series	EG 160 M1	-	4	5.5	53.1	720	81.0	10.30	6.0	0.73	1.9	2	0.0753	76	118
	EG 160 M2	-	5.5	7.5	73.0	720	83.0	13.60	6.0	0.74	2.0	2	0.0931	76	119
	EG 160 L	-	7.5	10	99.5	720	85.5	17.80	6.0	0.75	2.0	2	0.1260	76	145
	EG 180 L	-	11	15	143.9	730	87.5	25.10	6.6	0.76	2.0	2	0.2030	78	184
	EG 200 L	-	15	20	196.2	730	88.0	34.10	6.6	0.76	2.0	2	0.3390	80	250
	EG 225 S	-	18.5	25	242.0	730	90.0	41.10	6.6	0.76	1.9	2	0.4910	80	266
	EG 225 M	-	22	30	283.9	740	90.5	47.40	6.6	0.78	1.9	2	0.5470	80	292
	EG 250 M	-	30	40	387.2	740	91.0	63.40	6.6	0.79	1.9	2	0.8340	82	405
	EG 280 S	-	37	50	477.5	740	91.5	78.00	6.6	0.79	1.9	2	1.3900	83	520
	EG 280 M1	-	45	60	580.7	740	92.0	94.00	6.6	0.79	1.9	2	1.6500	82	592
	EG 315 S	-	55	75	709.8	740	92.8	111.00	6.6	0.81	1.8	2	4.7900	88	1000
	EG 315 M	-	75	100	967.9	740	93.0	151.00	6.6	0.81	1.8	2	5.5800	88	1100
EG 315 L1	-	90	125	1161.5	740	93.8	178.00	6.6	0.82	1.8	2	6.3700	88	1160	
EG 315 L2	-	110	150	1419.6	740	94.0	217.00	6.4	0.82	1.8	2	7.2300	88	1230	

• Increased power.

* Electrical data change depending on the series. For further information, please contact to Cosgra. MSE and EGQ data.

Permanent capacitor

ASYNCHRONOUS SINGLE-PHASE MOTORS

Squirrel-case rotor.

External cooling IC 411, continuous duty S1

Insulation class 155 (F), protection degree IP55.

Aluminium motors **MY/MYT** series.

Synchronous speed 3000 rpm - 2 poles

230 V. 50 Hz

	TYPE	Power		n rpm	I _N 230 V A	η %	Cosφ	M _r /M _N	M _s /M _N	I _A (A)	Run capacitor (μf/V)	Noise level dB(A)	m Kg	
		kW	hp											
Aluminium motors MY/MYT series	MY 56 1	-	0.09	0.12	2760	0.79	54	0.92	0.65	1.6	3	4 μf/450V	67	2.9
	MY 56 2	-	0.12	0.17	2770	0.98	58	0.92	0.65	1.6	4	6 μf/450V	67	3.2
	MYT 63 1	-	0.18	0.25	2700	1.47	56	0.95	0.65	1.7	5	10 μf/450V	70	4.0
	MYT 63 2	-	0.25	0.33	2700	2.00	57	0.95	0.65	1.7	7	12 μf/450V	70	4.5
	MYT 71 1	-	0.37	0.5	2710	2.61	65	0.95	0.70	1.7	10	20 μf/450V	75	5.1
	MYT 71 2	-	0.55	0.75	2740	3.70	68	0.95	0.70	1.7	15	25 μf/450V	75	7.2
	MYT 80 1	-	0.75	1	2740	4.90	70	0.95	0.75	1.7	20	30 μf/450V	75	9.6
	MYT 80 2	-	1.1	1.5	2740	6.83	73	0.96	0.75	1.7	30	40 μf/450V	78	11.0
	MYT 90 S	-	1.5	2	2750	9.18	74	0.96	0.75	1.7	45	50 μf/450V	80	14.0
	MYT 90 L	-	2.2	3	2750	13.11	76	0.96	0.60	1.7	65	60 μf/450V	80	16.5
	MYT 100 L	-	3	4	2750	17.20	79	0.96	0.60	1.7	75	70 μf/450V	83	25.0

Synchronous speed 1500 rpm - 4 poles

230 V. 50 Hz

	TYPE	Power		n rpm	I _N 230 V A	η %	Cosφ	M _r /M _N	M _s /M _N	I _A (A)	Run capacitor (μf/V)	Noise level dB(A)	m Kg	
		kW	hp											
Aluminium motors MY/MYT series	MY 56 1	-	0.06	0.09	1360	0.59	48	0.92	0.75	1.6	2.5	4 μf/450V	63	3.5
	MYT 56 2	-	0.09	0.12	1370	0.85	50	0.92	0.75	1.7	2.5	6 μf/450V	63	3.8
	MYT 63 1	-	0.12	0.17	1380	1.10	52	0.92	0.75	1.7	3.5	10 μf/450V	65	4.0
	MYT 63 2	-	0.18	0.25	1380	1.61	53	0.95	0.75	1.7	5.0	12 μf/450V	65	4.6
	MYT 71 1	-	0.25	0.33	1320	2.01	57	0.95	0.75	1.7	7.0	16 μf/450V	65	5.7
	MYT 71 2	-	0.37	0.5	1340	2.78	61	0.92	0.75	1.7	10.0	20 μf/450V	68	6.7
	MYT 80 1	-	0.55	0.75	1350	4.13	63	0.95	0.70	1.7	15.0	25 μf/450V	70	9.2
	MYT 80 2	-	0.75	1	1350	5.05	68	0.95	0.70	1.7	20.0	35 μf/450V	70	9.0
	MYT 90 S	-	1.1	1.5	1350	7.09	71	0.95	0.65	1.7	30.0	45 μf/450V	73	14.5
	MYT 90 L	-	1.5	2	1370	9.28	74	0.95	0.65	1.7	45.0	50 μf/450V	75	16.2
	MYT 100 L1	-	2.2	3	1400	12.77	78	0.96	0.47	1.7	65.0	70 μf/450V	78	24.0
	MYT 100 L2	-	3	4	1400	17.20	79	0.96	0.47	1.7	75.0	90 μf/450V	80	32.0

Synchronous speed 1000 rpm - 6 poles

230 V. 50 Hz

	TYPE	Power		n rpm	I _N 230 V A	η %	Cosφ	M _r /M _N	M _s /M _N	I _A (A)	Run capacitor (μf/V)	Noise level dB(A)	m Kg	
		kW	hp											
Aluminium motors MY series	MY 63 1	-	0.09	0.12	900	0.92	46	0.92	0.55	1.45	2.00	8 μf/450V	63	5.1
	MY 63 2	-	0.12	0.16	900	1.05	54	0.92	0.55	1.45	3.00	11 μf/450V	63	6.0
	MY 71 1	-	0.18	0.25	851	1.33	52	0.95	0.40	1.70	4.65	10 μf/450V	68	6.3
	MY 71 2	-	0.25	0.33	856	2.00	54	0.95	0.40	1.70	8.00	14 μf/450V	68	7.6
	MY 80 1	-	0.37	0.55	861	3.00	55	0.95	0.40	1.70	15.0	20 μf/450V	68	9.0
	MY 80 2	-	0.55	0.75	863	4.50	56	0.95	0.40	1.70	27.0	20 μf/450V	70	11.6
	MY 90 S	-	0.75	1	890	5.60	60	0.95	0.45	1.70	33.6	25 μf/450V	70	13.5
	MY 90 L	-	1.1	1.5	891	7.50	63	0.95	0.45	1.60	45.0	40 μf/450V	70	16.2

* Electrical data change depending on the series. For further information, please contact to Cosgra. MYTE/MYE data.

(*) **Single-phase motor with permanent capacitor – low starting torque.** It has two identical windings and the capacitor is connected in series to one of them, so that the motor can operate staidly at full-load. Because of its low starting torque, this kind of motor is suitable for applications where torque at starting moment is low. CEMER MYT series have higher starting torque than other motors on the market.

Double capacitor (centrifugal switch) High starting torque

ASYNCHRONOUS SINGLE-PHASE MOTORS

Squirrel-case rotor.

External cooling IC 411, continuous duty S1

Insulation class 155 (F), protection degree IP55.

Aluminium motors **ML** series.

Synchronous speed 3000 rpm - 2 poles

230 V. 50 Hz

TYPE	Power		n rpm	I (Amp) 230 V	η %	Cos φ	M _A /M _N	M _S /M _N	I _A (A)	Run capacitor (μ f/V)	Start capacitor (μ f/V)	Noise level dB(A)	m Kg		
	kW	hp													
Aluminium motors ML series	ML 63 1	-	0.18	0.25	2750	1.38	63	0.90	2.5	1.6	8	8 μ f/450V	40 μ f/250V	70	4.0
	ML 63 2	-	0.25	0.33	2760	1.89	64	0.90	2.5	1.6	10	10 μ f/450V	50 μ f/250V	70	4.5
	ML 71 1	-	0.37	0.5	2780	2.61	67	0.92	2.5	1.7	15	12 μ f/450V	75 μ f/250V	72	6.1
	ML 71 2	-	0.55	0.75	2790	3.71	70	0.92	2.5	1.7	20	14 μ f/450V	100 μ f/250V	72	6.5
	ML 80 1	-	0.75	1	2800	4.92	72	0.92	2.5	1.7	30	20 μ f/450V	100 μ f/250V	75	9.0
	ML 80 2	-	1.1	1.5	2810	6.71	75	0.95	2.5	1.7	40	30 μ f/450V	150 μ f/250V	75	10.0
	ML 90 S	-	1.5	2	2810	9.03	76	0.95	2.5	1.8	55	40 μ f/450V	200 μ f/250V	78	13.0
	ML 90 L	-	2.2	3	2810	13.68	77	0.95	2.2	1.8	75	50 μ f/450V	250 μ f/250V	78	14.5
	ML 100 L	-	3	4	2830	17.38	79	0.95	2.2	2.0	95	50 μ f/450V	400 μ f/300V	83	25.0
	ML 112 M1	-	3.7	5	2850	20.52	80	0.98	2.0	2.0	120	60 μ f/450V	600 μ f/300V	84	35.0
ML 112 M2	-	4	5.5	2850	22.18	80	0.98	2.0	2.0	150	60 μ f/450V	600 μ f/300V	84	35.0	

Synchronous speed 1500 rpm - 4 poles

230 V. 50 Hz

TYPE	Power		n rpm	I (Amp) 230 V	η %	Cos φ	M _A /M _N	M _S /M _N	I _A (A)	Run capacitor (μ f/V)	Start capacitor (μ f/V)	Noise level dB(A)	m Kg		
	kW	hp													
Aluminium motors ML series	ML 63 1	-	0.12	0.17	1350	1.04	55	0.91	2.5	1.6	6.0	8 μ f/450V	35 μ f/250V	65	6.1
	ML 63 2	-	0.18	0.25	1360	1.54	56	0.91	2.5	1.6	8.5	10 μ f/450V	35 μ f/250V	65	6.5
	ML 71 1	-	0.25	0.33	1380	1.91	62	0.92	2.5	1.6	10.0	12 μ f/450V	75 μ f/250V	67	9.5
	ML 71 2	-	0.37	0.5	1380	2.69	65	0.92	2.5	1.5	15.0	16 μ f/450V	75 μ f/250V	67	10.5
	ML 80 1	-	0.55	0.75	1400	3.82	68	0.92	2.5	1.7	20.0	20 μ f/450V	100 μ f/250V	70	9.2
	ML 80 2	-	0.75	1	1410	4.99	71	0.92	2.5	1.7	30.0	25 μ f/450V	150 μ f/250V	70	9.0
	ML 90 S	-	1.1	1.5	1410	6.90	73	0.95	2.2	1.8	40.0	35 μ f/450V	200 μ f/250V	73	13.5
	ML 90 L	-	1.5	2	1420	9.15	75	0.95	2.2	1.8	55.0	40 μ f/450V	250 μ f/250V	73	14.5
	ML 100 L1	-	2.2	3	1430	13.25	76	0.93	2.2	1.8	75.0	50 μ f/450V	400 μ f/250V	78	24.0
	ML 100 L2	-	3	4	1440	17.83	77	0.95	2.2	1.8	95.0	60 μ f/450V	500 μ f/250V	78	28.5
	ML 112 M1	-	3.7	5	1440	20.72	80	0.97	2.2	1.8	120.0	70 μ f/450V	600 μ f/300V	78	28.5
	ML 112 M2	-	4	5.5	1440	22.41	80	0.97	2.2	1.7	150.0	70 μ f/450V	600 μ f/300V	78	28.5

* Electrical data change depending on the series. For further information, please contact to Cosgra. MLE data.

(*) **Single-phase motor (centrifugal switch) – high starting torque.** In addition to the run capacitor, connected in series, there is a second capacitor which increases the torque during the starting period and is disconnected from the start circuit when the rotation is stable (with the run capacitor). This kind of motor is suitable for applications where torque at starting moment is strong.

ASYNCHRONOUS THREE-PHASE ELECTROMAGNETIC BRAKE MOTORS

Squirrel-cage rotor.
External cooling IC 411, continuous duty S1.
Insulation class 155 (F), Protection degree IP 54.

AC brake.
Aluminium motors **IE1-MSEFA** series.

Synchronous speed 3000 rpm - 2 poles

400 V. 50 Hz

TYPE	Power		n rpm	AC TYPE	Mf N.m	Power W	I _n 230 V A	I _n 400 V A	Air gap mm	Noise level dB(A)	m Kg
	kW	hp									
MSEFA 63 1 -	0.18	0.25	2710								5.2
MSEFA 63 2 -	0.25	0.33	2710	AC01	4.5	17	0.10	0.05	0.15 ÷ 0.5	68	5.3
• MSEFA 63 3 -	0.37	0.5	2710								6.1
MSEFA 71 1 -	0.37	0.5	2730								7.8
MSEFA 71 2 -	0.55	0.75	2760	AC02	10.0	22	0.17	0.10	0.2 ÷ 0.6	69	8.1
• MSEFA 71 3 -	0.75	1.1	2730								8.9
IE1 - MSEFA 80 1 -	0.75	1.1	2760								11.4
IE1 - MSEFA 80 2 -	1.1	1.5	2760	AC03	16.0	27	0.21	0.12	0.2 ÷ 0.6	70	12.2
• MSEFA 80 3 -	1.5	2	2790								14.0
IE1 - MSEFA 90 S -	1.5	2	2820								15.3
IE1 - MSEFA 90 L1 -	2.2	3	2820	AC04	20.0	27	0.30	0.17	0.2 ÷ 0.7	69	18.0
• MSEFA 90 L2 -	3	4	2830								21.6
IE1 - MSEFA 100 L1 -	3	4	2840								27.3
• MSEFA 100 L2 -	4	5.5	2850	AC05	40.0	39	0.69	0.40	0.2 ÷ 0.7	70	29.5
IE1 - MSEFA 112 M -	4	5.5	2850								35.5
• MSEFA 112 L2 -	5.5	7.5	2860	AC06	60.0	61	0.75	0.43	0.2 ÷ 0.7	70	37.7
IE1 - MSEFA 132 S1 -	5.5	7.5	2860								47.5
IE1 - MSEFA 132 S2 -	7.5	10	2910								54.5
• MSEFA 132 M1 -	9.2	12.5	2910	AC07	90.0	69	1.25	0.72	0.2 ÷ 0.7	70	62.9
• MSEFA 132 M2 -	11	15	2930								70.3
IE1 - MSEFA 160 M1 -	11	15	2930								90.0
IE1 - MSEFA 160 M2 -	15	20	2940	AC08	200.0	134	1.50	0.86	0.2 ÷ 0.7	70	103.0
IE1 - MSEFA 160 L2 -	18.5	25	2940								114.0

Synchronous speed 1500 rpm - 4 poles

400 V. 50 Hz

TYPE	Power		n rpm	AC TYPE	Mf N.m	Power W	I _n 230 V A	I _n 400 V A	Air gap mm	Noise level dB(A)	m Kg
	kW	hp									
MSEFA 63 1 -	0.12	0.17	1320								4.9
MSEFA 63 2 -	0.18	0.25	1350	AC01	4.5	17	0.10	0.05	0.15 ÷ 0.5	68	5.4
• MSEFA 63 3 -	0.25	0.33	1350								6.2
MSEFA 71 1 -	0.25	0.33	1350								6.8
MSEFA 71 2 -	0.37	0.5	1370	AC02	10.0	22	0.17	0.10	0.2 ÷ 0.6	69	7.6
• MSEFA 71 3 -	0.55	0.75	1380								8.3
MSEFA 80 1 -	0.55	0.75	1380								10.4
IE1 - MSEFA 80 2 -	0.75	1	1380	AC03	16.0	27	0.21	0.12	0.2 ÷ 0.6	70	11.4
• MSEFA 80 3 -	1.1	1.5	1390								13.3
IE1 - MSEFA 90 S -	1.1	1.5	1390								14.7
IE1 - MSEFA 90 L1 -	1.5	2	1400	AC04	20.0	27	0.30	0.17	0.2 ÷ 0.7	69	17.4
• MSEFA 90 L2 -	2.2	3	1410								20.6
IE1 - MSEFA 100 L1 -	2.2	3	1410								24.2
IE1 - MSEFA 100 L2 -	3	4	1420	AC05	40.0	39	0.69	0.40	0.2 ÷ 0.7	70	27.5
• MSEFA 100 L3 -	4	5.5	1430								32.3
IE1 - MSEFA 112 M -	4	5.5	1430								36.5
• MSEFA 112 L -	5.5	7.5	1440	AC06	60.0	61	0.75	0.43	0.2 ÷ 0.7	70	43.2
IE1 - MSEFA 132 S -	5.5	7.5	1440								50.5
IE1 - MSEFA 132 M -	7.5	10	1450								60.1
• MSEFA 132 L1 -	9.2	12.5	1450	AC07	90.0	69	1.25	0.72	0.2 ÷ 0.7	70	68.0
• MSEFA 132 L2 -	11	15	1460								75.5
IE1 - MSEFA 160 M -	11	15	1460								88.0
IE1 - MSEFA 160 L -	15	20	1460	AC08	200.0	134	1.50	0.86	0.2 ÷ 0.7	70	103.5

• Increased power. * Electrical data change depending on the series. For further information, please contact to Cosgra.

ASYNCHRONOUS THREE-PHASE ELECTROMAGNETIC BRAKE MOTORS

Squirrel-cage rotor.
External cooling IC 411, continuous duty S1.
Insulation class 155 (F), Protection degree IP 54.

AC brake.
Aluminium motors **IE1-MSEFA** series.

Synchronous speed 1000 rpm - 6 poles

400 V. 50 Hz

	TYPE	Power		n rpm	AC TYPE	Mf N.m	Power W	I _N 230 V A	I _N 400 V A	Air gap mm	Noise level dB(A)	m Kg	
		kW	hp										
Aluminium brake motors IE1-MSEFA series	MSEFA 63 1	-	0.09	0.12	840	AC01	4.5	17	0.10	0.05	0.15 ÷ 0.5	68	5.4
	MSEFA 63 2	-	0.12	0.17	840								5.7
	MSEFA 71 1	-	0.18	0.25	860	AC02	10.0	22	0.17	0.10	0.2 ÷ 0.6	69	7.4
	MSEFA 71 2	-	0.25	0.33	860								7.8
	• MSEFA 71 3	-	0.37	0.5	875								8.6
	MSEFA 80 1	-	0.37	0.5	890	AC03	16.0	27	0.21	0.12	0.2 ÷ 0.6	70	10.4
	MSEFA 80 2	-	0.55	0.75	900								11.9
	• MSEFA 80 3	-	0.75	1	900								12.3
	IE1 - MSEFA 90 S	-	0.75	1	920	AC04	20.0	27	0.30	0.17	0.2 ÷ 0.7	69	14.3
	IE1 - MSEFA 90 L1	-	1.1	1.5	920								17.4
	IE1 - MSEFA 100 L1	-	1.5	2	935	AC05	40.0	39	0.69	0.40	0.2 ÷ 0.7	70	23.8
	IE1 - MSEFA 112 M	-	2.2	3	940	AC06	60.0	61	0.75	0.43	0.2 ÷ 0.7	70	32.5
	IE1 - MSEFA 132 S	-	3	4	940	AC07	90.0	69	1.25	0.72	0.2 ÷ 0.7	70	46.5
	IE1 - MSEFA 132 M1	-	4	5.5	950								59.1
	IE1 - MSEFA 132 M2	-	5.5	7.5	950								62.2
	• MSEFA 132 L	-	7.5	10	950								59.1
	IE1 - MSEFA 160 M	-	7.5	10	950	AC08	200.0	134	1.50	0.86	0.2 ÷ 0.7	70	85.0
	IE1 - MSEFA 160 L	-	11	15	950								102.0

Synchronous speed 750 rpm - 8 poles

400 V. 50 Hz

	TYPE	Power		n rpm	AC TYPE	Mf N.m	Power W	I _N 230 V A	I _N 400 V A	Air gap mm	Noise level dB(A)	m Kg	
		kW	hp										
Aluminium brake motors IE1-MSEFA series	MSEFA 71 1	-	0.09	0.12	590	AC02	10	22	0.17	0.10	0.2 ÷ 0.6	69	7.4
	MSEFA71 2	-	0.12	0.17	595								7.8
	MSEFA80 1	-	0.18	0.25	610	AC03	16	27	0.21	0.12	0.2 ÷ 0.6	70	11.7
	MSEFA80 2	-	0.25	0.33	620								12.4
	MSEFA90 S	-	0.37	0.5	660	AC04	20	27	0.30	0.17	0.2 ÷ 0.7	69	15.5
	MSEFA90 L	-	0.55	0.75	660								18.3
	MSEFA100 L1	-	0.75	1	690	AC05	40	39	0.69	0.40	0.2 ÷ 0.7	70	22.2
	MSEFA100 L2	-	1.1	1.5	690								24.5
	MSEFA112 M	-	1.5	2	690	AC06	60	61	0.75	0.43	0.2 ÷ 0.7	70	33.0
	MSEFA132 S	-	2.2	3	710	AC07	90	69	1.25	0.72	0.2 ÷ 0.7	70	45.7
	MSEFA132 M	-	3	4	710								51.5
	MSEFA160 M1	-	4	5.5	720	AC08	200	134	1.50	0.86	0.2 ÷ 0.7	70	74.0
	MSEFA160 M2	-	5.5	7.5	720								84.0
	MSEFA160 L	-	7.5	10	720								102.0

• Increased power.

* Electrical data change depending on the series. For further information, please contact to Cosgra. MSE data.

ASYNCHRONOUS THREE-PHASE ELECTROMAGNETIC BRAKE MOTORS

Squirrel-cage rotor.
External cooling IC 411, continuous duty S1.
Insulation class 155 (F), Protection degree IP 54.

DC brake.
Aluminium motors **IE1-MSEFC** series.

Synchronous speed 3000 rpm - 2 poles

400 V. 50 Hz

TYPE	Power		n rpm	DC TYPE	Mf N.m	Power W	I _n 230 V A	I _n 400 V A	Air gap mm	Noise level dB(A)	m Kg
	kW	hp									
MSEFC 63 1 -	0.18	0.25	2710								5.1
MSEFC 63 2 -	0.25	0.33	2710	K01	5	15	0.06	0.03	0.15 ÷ 0.5	68	5.3
• MSEFC 63 3 -	0.37	0.5	2710								5.8
MSEFC 71 1 -	0.37	0.5	2730								7.1
MSEFC 71 2 -	0.55	0.75	2760	K02	12	20	0.09	0.05	0.2 ÷ 0.6	69	7.9
• MSEFC 71 3 -	0.75	1	2730								8.9
IE1 - MSEFC 80 1 -	0.75	1	2760								11.3
IE1 - MSEFC 80 2 -	1.1	1.5	2760	K03	16	25	0.10	0.06	0.2 ÷ 0.6	68	12.6
• MSEFC 80 3 -	1.5	2	2790								13.8
IE1 - MSEFC 90 S -	1.5	2	2820								14.8
IE1 - MSEFC 90 L1 -	2.2	3	2820	K04	20	30	0.13	0.07	0.2 ÷ 0.7	69	17.3
• MSEFC 90 L2 -	3	4	2830								17.8
IE1 - MSEFC 100 L1 -	3	4	2840								24.8
• MSEFC 100 L2 -	4	5.5	2850	K05	40	45	0.19	0.17	0.2 ÷ 0.7	70	28.8
IE1 - MSEFC 112 M -	4	5.5	2850								33.0
• MSEFC 112 L2 -	5.5	7.5	2860	K06	60	50	0.22	0.13	0.2 ÷ 0.7	70	36.3
IE1 - MSEFC 132 S1 -	5.5	7.5	2860								50.4
IE1 - MSEFC 132 S2 -	7.5	10	2910								53.3
• MSEFC 132 M1 -	9.2	12.5	2910	K07	90	55	0.24	0.14	0.2 ÷ 0.7	70	60.2
• MSEFC 132 M2 -	11	15	2930								64.5
IE1 - MSEFC 160 M1 -	11	15	2930								90.3
IE1 - MSEFC 160 M2 -	15	20	2940	K08	200	60	0.27	0.15	0.2 ÷ 0.7	70	91.8
IE1 - MSEFC 160 L2 -	18.5	25	2940								106.3

Aluminium brake motors IE1-MSEFC series

Synchronous speed 1500 rpm - 4 poles

400 V. 50 Hz

TYPE	Power		n rpm	DC TYPE	Mf N.m	Power W	I _n 230 V A	I _n 400 V A	Air gap mm	Noise level dB(A)	m Kg
	kW	hp									
MSEFC 63 1 -	0.12	0.17	1320								4.8
MSEFC 63 2 -	0.18	0.25	1350	K01	5	15	0.06	0.03	0.15 ÷ 0.5	68	5.3
• MSEFC 63 3 -	0.25	0.33	1350								6.1
MSEFC 71 1 -	0.25	0.33	1350								6.9
MSEFC 71 2 -	0.37	0.5	1370	K02	12	20	0.09	0.05	0.2 ÷ 0.6	69	7.7
• MSEFC 71 3 -	0.55	0.75	1380								8.4
MSEFC 80 1 -	0.55	0.75	1380								10.7
IE1 - MSEFC 80 2 -	0.75	1	1380	K03	16	25	0.10	0.06	0.2 ÷ 0.6	70	11.7
• MSEFC 80 3 -	1.1	1.5	1390								13.6
IE1 - MSEFC 90 S -	1.1	1.5	1390								14.5
IE1 - MSEFC 90 L1 -	1.5	2	1400	K04	20	30	0.13	0.07	0.2 ÷ 0.7	69	17.2
• MSEFC 90 L2 -	2.2	3	1410								20.4
IE1 - MSEFC 100 L1 -	2.2	3	1410								24.0
IE1 - MSEFC 100 L2 -	3	4	1420	K05	40	45	0.19	0.11	0.2 ÷ 0.7	70	27.1
• MSEFC 100 L3 -	4	5.5	1430								32.1
IE1 - MSEFC 112 M -	4	5.5	1430								36.0
• MSEFC 112 L -	5.5	7.5	1440	K06	60	50	0.22	0.13	0.2 ÷ 0.7	70	42.7
IE1 - MSEFC 132 S -	5.5	7.5	1440								51.0
IE1 - MSEFC 132 M -	7.5	10	1450								60.6
• MSEFC 132 L1 -	9.2	12.5	1450	K07	90	55	0.24	0.14	0.2 ÷ 0.7	70	68.5
• MSEFC 132 L2 -	11	15	1460								76.0
IE1 - MSEFC 160 M -	11	15	1460								87.3
IE1 - MSEFC 160 L -	15	20	1460	K08	200	60	0.27	0.15	0.2 ÷ 0.7	70	102.8

Aluminium brake motors IE1-MSEFC series

• Increased power. * Electrical data change depending on the series. For further information, please contact to Cosgra. MSE data.

ASYNCHRONOUS THREE-PHASE ELECTROMAGNETIC BRAKE MOTORS

Squirrel-cage rotor.
External cooling IC 411, continuous duty S1.
Insulation class 155 (F), Protection degree IP 54.

DC brake.
Aluminium motors **IE1-MSEFC** series.

Synchronous speed 1000 rpm - 6 poles

400 V. 50 Hz

	TYPE	Power		n rpm	DC TYPE	Mf N.m	Power W	I _N 230 V A	I _N 400 V A	Air gap mm	Noise level dB(A)	m Kg
		kW	hp									
Aluminium brake motors IE1-MSEFC series	MSEFC63 1 -	0.09	0.12	840	K01	5	15	0.06	0.03	0.15 ÷ 0.5	68	5.3
	MSEFC63 2 -	0.12	0.17	840								5.6
	MSEFC71 1 -	0.18	0.25	860	K02	12	20	0.09	0.05	0.2 ÷ 0.6	69	7.5
	MSEFC71 2 -	0.25	0.33	860								7.9
	• MSEFC71 3 -	0.37	0.5	875								8.7
	MSEFC80 1 -	0.37	0.5	890	K03	16	25	0.10	0.06	0.2 ÷ 0.6	70	10.7
	MSEFC80 2 -	0.55	0.75	900								12.2
	• MSEFC80 3 -	0.75	1	900								12.6
	IE1 - MSEFC90 S -	0.75	1	920								14.1
	IE1 - MSEFC90 L1 -	1.1	1.5	920	K04	20	30	0.13	0.07	0.2 ÷ 0.7	69	17.2
	IE1 - MSEFC100 L1 -	1.5	2	935								23.6
	IE1 - MSEFC112 M -	2.2	3	940	K06	60	50	0.22	0.13	0.2 ÷ 0.7	70	32.0
	IE1 - MSEFC132 S -	3	4	940								47.0
	IE1 - MSEFC132 M1 -	4	5.5	950	K07	90	55	0.24	0.14	0.2 ÷ 0.7	70	59.6
	IE1 - MSEFC132 M2 -	5.5	7.5	950								62.7
	• MSEFC132 L -	7.5	10	950								59.6
	IE1 - MSEFC160 M -	7.5	10	950								85.0
IE1 - MSEFC160 L -	11	15	950	K08	200	60	0.27	0.15	0.2 ÷ 0.7	70	102.0	

Synchronous speed 750 rpm - 8 poles

400 V. 50 Hz

	TYPE	Power		n rpm	DC TYPE	Mf N.m	Power W	I _N 230 V A	I _N 400 V A	Air gap mm	Noise level dB(A)	m Kg
		kW	hp									
Aluminium brake motors IE1-MSEFA series	MSEFC71 1 -	0.09	0.12	590	K02	12	20	0.09	0.05	0.2 ÷ 0.6	69	7.5
	MSEFC71 2 -	0.12	0.17	595								7.9
	MSEFC80 1 -	0.18	0.25	610	K03	16	25	0.10	0.06	0.2 ÷ 0.6	70	12.0
	MSEFC80 2 -	0.25	0.33	620								12.7
	MSEFC90 S -	0.37	0.5	660	K04	20	30	0.13	0.07	0.2 ÷ 0.7	69	15.3
	MSEFC90 L -	0.55	0.75	660								18.1
	MSEFC100 L1 -	0.75	1	690	K05	40	45	0.19	0.11	0.2 ÷ 0.7	70	22.0
	MSEFC100 L2 -	1.1	1.5	690								24.3
	MSEFC112 M -	1.5	2	690	K06	60	50	0.22	0.13	0.2 ÷ 0.7	70	32.5
	MSEFC132 S -	2.2	3	710								46.2
	MSEFC132 M -	3	4	710	K07	90	55	0.24	0.14	0.2 ÷ 0.7	70	52.0
	MSEFC160 M1 -	4	5.5	720								74.0
	MSEFC160 M2 -	5.5	7.5	720								84.0
	MSEFC160 L -	7.5	10	720	K08	200	60	0.27	0.15	0.2 ÷ 0.7	70	102.0

• Increased power.

* Electrical data change depending on the series. For further information, please contact to Cosgra. MSE data.

DIMENSIONS

EFFICIENCY IE3 - ALUMINIUM

ASYNCHRONOUS THREE-PHASE MOTORS

Aluminium motors **IE3-MS** series.
Mounting positions **B3 - B5 - B5R - B14 - B14G**.

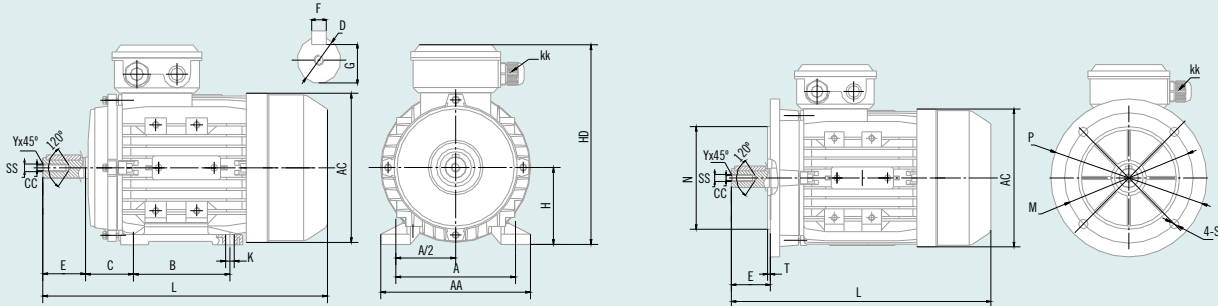

Frame	IM B3 / IM 1001										SHAFT END Tolerance j6					IM B5 / IM 3001 4 holes 45°				
	A	AA	AC	B	C	H	HD	K	KK	L	D	SS	E	F	G	M	N	P	S	T
80	125	155	158	100	50	80	212	10x13	1-M20x1.5	295	19	M6	40	6	15.5	165	130	200	12	3.5
90S	140	180	179	100	56	90	222	10x13	1-M20x1.5	335	24	M8	50	8	20.0	165	130	200	12	3.5
90L	140	180	179	125	56	90	222	10x13	1-M20x1.5	365	24	M8	50	8	20.0	165	130	200	12	3.5
100	160	200	202	140	63	100	251	12x16	1-M20x1.5	400	28	M10	60	8	24.0	215	180	250	15	4.0
112	190	233	225	140	70	112	278	12x16	2-M25x1.5	400	28	M10	60	8	24.0	215	180	250	15	4.0
132S	216	255	260	140	89	132	321	12x16	2-M25x1.5	430	38	M12	80	10	33.0	265	230	300	15	4.0
132M	216	255	260	178	89	132	321	12x16	2-M25x1.5	480	38	M12	80	10	33.0	265	230	300	15	4.0
160M	254	290	320	210	108	160	390	15x19	2-M32x1.5	640	42	M16	110	12	37.0	300	250	350	19	5.0
160L	254	290	320	254	108	160	390	15x19	2-M32x1.5	640	42	M16	110	12	37.0	300	250	350	19	5.0

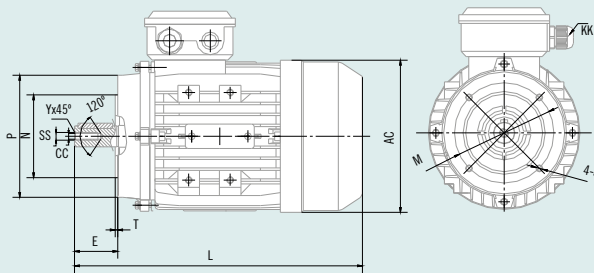

Frame	IM B5R 4 holes 45°					IM B14 / IM 3601 4 holes 45°					IM B14G / IM 3601 G 4 holes 45°						
	M	N	P	S	T	M	N	P	S	T	M	N	P	S	T		
80	130	110	160	12	3.5	80	100	80	120	M6	3.0	80	130	110	160	M8	3.5
90	130	110	160	12	3.5	90	115	95	140	M8	3.0	90	130	110	160	M8	3.5
100	165	130	200	15	3.5	100	130	110	160	M8	3.5	100	165	130	200	M10	3.5
112	165	130	200	15	3.5	112	130	110	160	M8	3.5	112	165	130	200	M10	3.5
132	215	180	250	15	4.0	132	165	130	200	M10	4.0	132	215	180	250	M12	4.0
160						160	215	180	250	M12	4.0						

* Dimensions change depending on the motor series. Please contact to Cosgra for further information. MSE dimensions.

ASYNCHRONOUS THREE-PHASE MOTORS

Aluminium motors **IE2-MS** series.
Mounting positions
B3 - B5 - B5R - B14 - B14G.

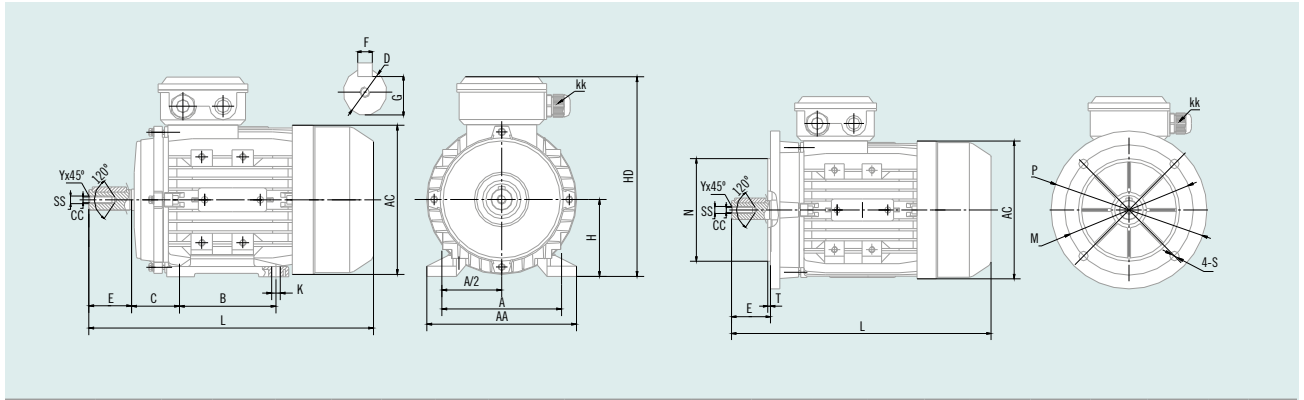

Frame	IM B3 / IM 1001										SHAFT END Tolerance j6					IM B5 / IM 3001 4 holes 45°				
	A	AA	AC	B	C	H	HD	K	KK	L	D	SS	E	F	G	M	N	P	S	T
80	125	155	158	100	50	80	210	10x13	1-M20x1.5	295	19	M6	40	6	15.5	165	130	200	12	3.5
90S	140	180	179	100	56	90	228	10x13	1-M20x1.5	320	24	M8	50	8	20.0	165	130	200	12	3.5
90L	140	180	179	125	56	90	228	10x13	1-M20x1.5	345	24	M8	50	8	20.0	165	130	200	12	3.5
100	160	200	202	140	63	100	260	12x16	1-M20x1.5	385	28	M10	60	8	24.0	215	180	250	15	4.0
112	190	233	225	140	70	112	285	12x16	2-M25x1.5	410	28	M10	60	8	24.0	215	180	250	15	4.0
132S	216	255	260	140	89	132	325	12x16	2-M25x1.5	470	38	M12	80	10	33.0	265	230	300	15	4.0
132M	216	255	260	178	89	132	325	12x16	2-M25x1.5	510	38	M12	80	10	33.0	265	230	300	15	4.0
160M	254	290	320	210	108	160	390	15x19	2-M32x1.5	640	42	M16	110	12	37.0	300	250	350	19	5.0
160L	254	290	320	254	108	160	390	15x19	2-M32x1.5	640	42	M16	110	12	37.0	300	250	350	19	5.0

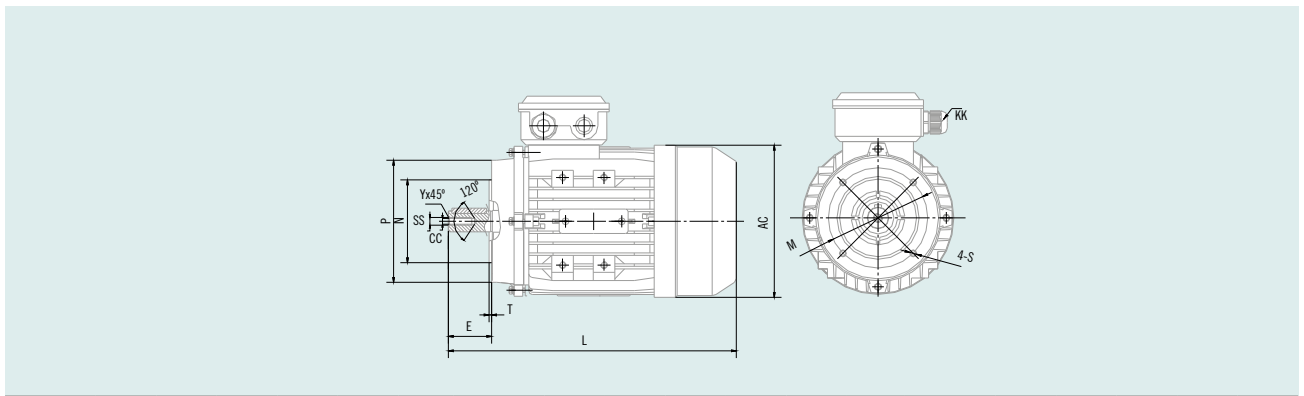

Frame	IM B5R 4 holes 45°					IM B14 / IM 3601 4 holes 45°					IM B14G / IM 3601 G 4 holes 45°						
	M	N	P	S	T	M	N	P	S	T	M	N	P	S	T		
80	130	110	160	12	3.5	80	100	80	120	M6	3.0	80	130	110	160	M8	3.5
90	130	110	160	12	3.5	90	115	95	140	M8	3.0	90	130	110	160	M8	3.5
100	165	130	200	15	3.5	100	130	110	160	M8	3.5	100	165	130	200	M10	3.5
112	165	130	200	15	3.5	112	130	110	160	M8	3.5	112	165	130	200	M10	3.5
132	215	180	250	15	4.0	132	165	130	200	M10	4.0	132	215	180	250	M12	4.0
160						160	215	180	250	M12	4.0						

* Dimensions change depending on the motor series. Please contact to Cosgra for further information. MSE dimensions.

EFFICIENCY IE1 - ALUMINIUM

ASYNCHRONOUS THREE-PHASE MOTORS

Aluminium motors **IE1-MS** series.
Mounting positions **B3 - B5 - B5R - B14 - B14G**.

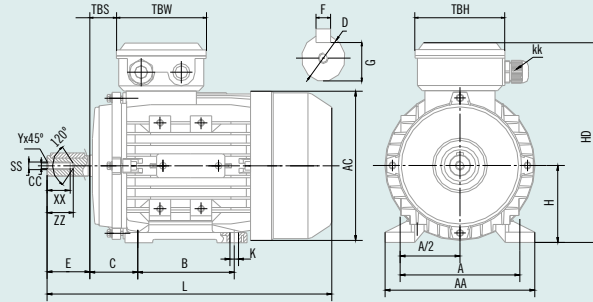

Frame	IM B3 / IM 1001													SHAFT END Tolerance j6						
	A	AA	AC	B	C	H	HD	K	KK	L	TBS	TBW	TBH	D	E	F	G	SS	XX	ZZ
56	90	110	117	71	36	56	156	5.8x5.8	1-M16x1.5	196	14	88	88	9	20	3	7.2	M3	9	12
63	100	120	130	80	40	63	173	7x10	1-M16x1.5	230	14	94	94	11	23	4	8.5	M4	10	14
71	112	132	147	90	45	71	188	7x10	1-M20x1.5	260	20	94	94	14	30	5	11.0	M5	12	17
80	125	160	163	100	50	80	217	10x13	1-M20x1.5	295	27	105	105	19	40	6	15.5	M6	16	21
90S	140	175	183	100	56	90	235	10x13	1-M20x1.5	315	30	105	105	24	50	8	20.0	M8	19	25
90L1	140	175	183	125	56	90	235	10x13	1-M20x1.5	335	30	105	105	24	50	8	20.0	M8	19	25
90L2	140	175	183	125	56	90	235	10x13	1-M20x1.5	365	30	105	105	24	50	8	20.0	M8	19	25
100*	160	198	205	140	63	100	253	12x15	2-M20x1.5	380 (400)	26	105	105	28	60	8	24.0	M10	22	30
112	190	220	229	140	70	112	282	12x15	2-M25x1.5	400	32	112	112	28	60	8	24.0	M10	22	30
132S	216	252	265	140	89	132	325	12x15	2-M25x1.5	440	38	112	112	38	80	10	33.0	M12	28	37
132M	216	252	265	178	89	132	325	12x15	2-M25x1.5	480	38	112	112	38	80	10	33.0	M12	28	37
132L	216	252	265	178	89	132	325	12x15	2-M25x1.5	500	38	112	112	38	80	10	33.0	M12	28	37
160M	254	290	325	210	108	160	390	15x19	2-M32x1.5	640	64	143	146	42	110	12	37.0	M16	36	45
160L	254	290	325	254	108	160	390	15x19	2-M32x1.5	640	64	143	146	42	110	12	37.0	M16	36	45

* Increased power (IEC frame).

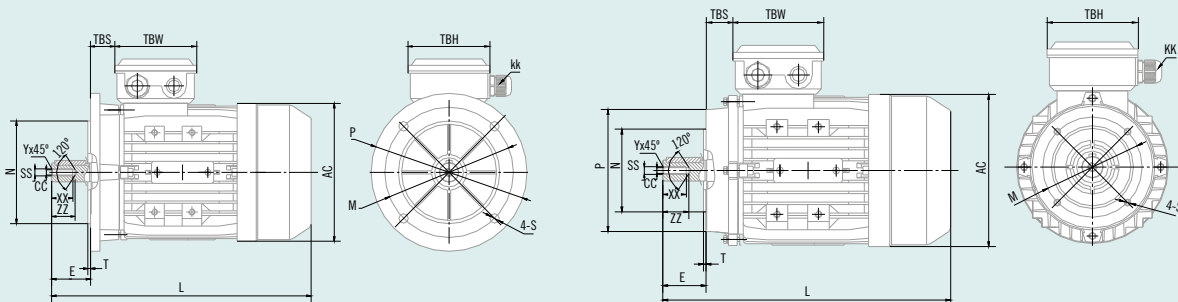

Frame	IM B5 / IM 3001 4 holes 45°					IM B5R 4 holes 45°					IM B14 / IM 3601 4 holes 45°					IM B14G / IM 3601 G 4 holes 45°				
	M	N	P	S	T	M	N	P	S	T	M	N	P	S	T	M	N	P	S	T
56	100	80	120	7	3.0	NON AVAILABLE					65	50	80	M5	2.5	NON AVAILABLE				
63	115	95	140	10	3.0	NON AVAILABLE					75	60	90	M5	2.5	100	80	120	M6	2.5
71	130	110	160	10	3.5	115	95	140	10	3.0	85	70	105	M6	2.5	115	95	140	M8	3.0
80	165	130	200	12	3.5	130	110	160	10	3.5	100	80	120	M6	3.0	130	110	160	M8	3.5
90	165	130	200	12	3.5	130	110	160	10	3.5	115	95	140	M8	3.0	130	110	160	M8	3.5
100	215	180	250	15	4.0	165	130	200	12	3.5	130	110	160	M8	3.5	165	130	200	M10	3.5
112	215	180	250	15	4.0	165	130	200	12	3.5	130	110	160	M8	3.5	165	130	200	M10	3.5
132	265	230	300	15	4.0	215	180	250	15	4.0	165	130	200	M10	4.0	215	180	250	M12	4.0
160	300	250	350	19	5.0	NON AVAILABLE					215	180	250	M12	4.0	NON AVAILABLE				

* Dimensions change depending on the motor series. Please contact to Cosgra for further information. MSE dimensions.

ASYNCHRONOUS THREE-PHASE MOTORS

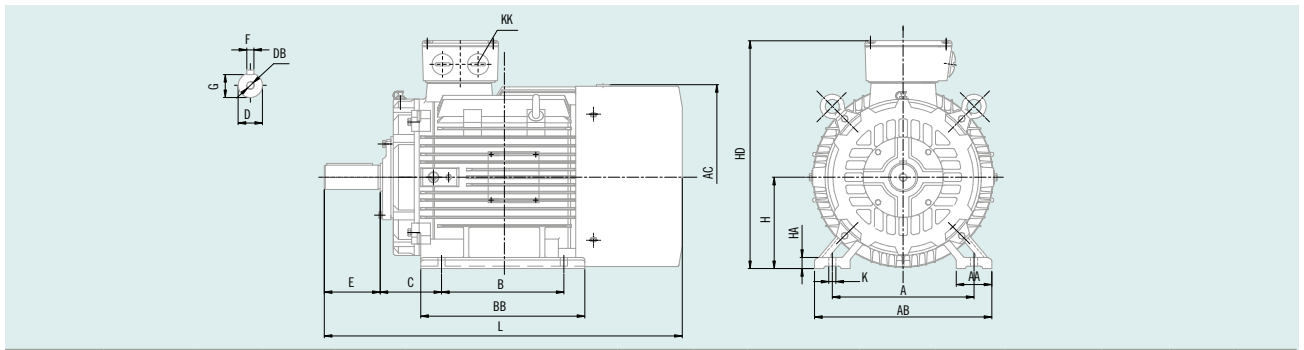

Frame	Poles	IM B3 / IM 1001										SHAFT END				
		A	AB	AC	B	C	H	HD	K	KK	L	D	DB	E	F	G
160 M	2-4-6	254	320	330	214	108	160	420	15	2-M40x1.5	700	42	M16x36	110	12	37.0
160 L	2-4-6	254	320	330	254	108	160	420	15	2-M40x1.5	740	42	M16x36	110	12	37.0
180 M	2-4-6	279	355	380	241	121	180	455	15	2-M40x1.5	790	48	M16x36	110	14	42.5
180 L	2-4-6	279	355	380	279	121	180	455	15	2-M40x1.5	790	48	M16x36	110	14	42.5
200 L	2-4-6	318	395	420	305	133	200	505	19	2-M50x1.5	830	55	M20x42	110	16	49.0
225 S	4	356	435	470	286	149	225	560	19	2-M50x1.5	830	60	M20x42	140	18	53.0
225 M	2	356	435	470	311	149	225	560	19	2-M50x1.5	825	55	M20x42	110	16	49.0
225 M	4-6	356	435	470	311	149	225	560	19	2-M50x1.5	855	60	M20x42	140	18	53.0
250 M	2	406	490	510	349	168	250	615	24	2-M63x1.5	915	60	M20x42	140	18	53.0
250 M	4-6	406	490	510	349	168	250	615	24	2-M63x1.5	915	65	M20x42	140	18	58.0
280 S	2	457	550	580	368	190	280	680	24	2-M63x1.5	985	65	M20x42	140	18	58.0
280 S	4-6	457	550	580	368	190	280	680	24	2-M63x1.5	985	75	M20x42	140	20	67.5
280 M	2	457	550	580	419	190	280	680	24	2-M63x1.5	1035	65	M20x42	140	18	58.0
280 M	4-6	457	550	580	419	190	280	680	24	2-M63x1.5	1035	75	M20x42	140	20	67.5
315 S	2	508	635	645	406	216	315	845	28	2-M63x1.5	1180	65	M20x42	140	18	58.0
315 S	4-6	508	635	645	406	216	315	845	28	2-M63x1.5	1290	80	M20x42	170	22	71.0
315 M	2	508	635	645	457	216	315	845	28	2-M63x1.5	1210	65	M20x42	140	18	58.0
315 M	4-6	508	635	645	457	216	315	845	28	2-M63x1.5	1320	80	M20x42	170	22	71.0
315 L	2	508	635	645	508	216	315	845	28	2-M63x1.5	1210	65	M20x42	140	18	58.0
315 L	4-6	508	635	645	508	216	315	845	28	2-M63x1.5	1320	80	M20x42	170	22	71.0
355 M	2	610	730	710	560	254	355	1010	28	2-M72x2.0	1500	75	M24x50	140	20	67.5
355 M	4-6	610	730	710	560	254	355	1010	28	2-M72x2.0	1530	95	M24x50	170	25	86.0
355 L	2	610	730	710	630	254	355	1010	28	2-M72x2.0	1500	75	M24x50	140	20	67.5
355 L	4-6	610	730	710	630	254	355	1010	28	2-M72x2.0	1530	95	M24x50	170	25	86.0

* Shaft end tolerances: k6 up to D. 48. The rest, m6.

IM B5 / IM 3001						
Frame	P	N	M	S	T	LA
160	350	250	300	19	5	15
180	350	250	300	19	5	15
200	400	300	350	19	5	17
225	450	350	400	19	5	19
250	550	450	500	19	5	20
280	550	450	500	19	5	22
315	660	550	600	24	6	24
355	800	680	740	24	6	25

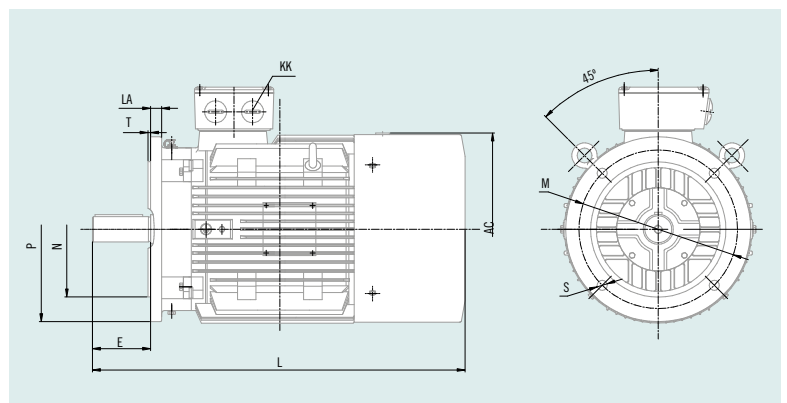

* Frames 160, 180 and 200, 4 holes 45°. The rest, 8 holes 22.5°.

* Dimensions change depending on the motor series. Please contact to Cosgra for further information. EGQ dimensions.

EFFICIENCY IE1 - IE2 - CAST IRON

Cast iron motors **IE1-IE2 EG** series.
Mounting positions **B3 - B5**.

ASYNCHRONOUS THREE-PHASE MOTORS

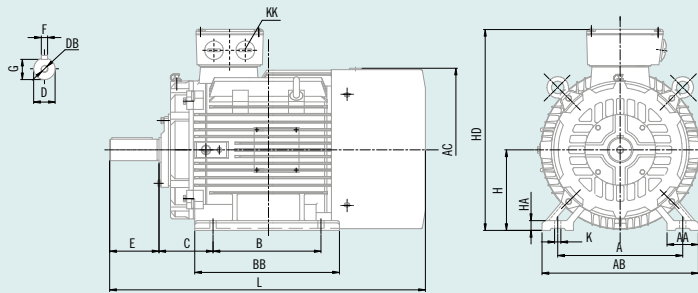

IM B3 / IM 1001															SHAFT END				
Frame	Poles	A	AA	AB	AC	B	BB	C	H	HA	HD	K	KK	L	D	DB	E	F	G
160M	2-8	254	73	320	330	210	318	108	160	20	420	15	2-M40x1.5	659	42	M16x36	110	12	37.0
160L	2-8	254	73	320	330	254	362	108	160	20	420	15	2-M40x1.5	714	42	M16x36	110	12	37.0
180M	2-8	279	73	355	380	241	349	121	180	22	455	15	2-M40x1.5	738	48	M16x36	110	14	42.5
180L	2-8	279	73	355	380	279	387	121	180	22	455	15	2-M40x1.5	778	48	M16x36	110	14	42.5
200L	2-8	318	73	395	400	305	375	133	200	25	505	19	2-M50x1.5	770	55	M20x42	110	16	49.0
225S	4-8	356	83	435	470	286	375	149	225	28	560	19	2-M50x1.5	820	60	M20x42	140	18	53.0
225M	2	356	83	435	470	311	400	149	225	28	560	19	2-M50x1.5	815	55	M20x42	110	16	49.0
225M	4-8	356	83	435	470	311	400	149	225	28	560	19	2-M50x1.5	845	60	M20x42	140	18	53.0
250M	2	406	88	490	510	349	450	168	250	30	615	24	2-M63x1.5	910	60	M20x42	140	18	53.0
250M	4-8	406	88	490	510	349	450	168	250	30	615	24	2-M63x1.5	910	65	M20x42	140	18	58.0
280S	2	457	93	550	547	368	490	190	280	35	680	24	2-M63x1.5	985	65	M20x42	140	18	58.0
280S	4-8	457	93	550	547	368	490	190	280	35	680	24	2-M63x1.5	985	75	M20x42	140	20	67.5
280M	2	457	93	550	547	419	540	190	280	35	680	24	2-M63x1.5	1035	65	M20x42	140	18	58.0
280M	4-8	457	93	550	547	419	540	190	280	35	680	24	2-M63x1.5	1035	75	M20x42	140	20	67.5
315S	2	508	120	635	645	406	575	216	315	45	845	28	2-M63x1.5	1185	65	M20x42	140	18	58.0
315S	4-8	508	120	635	645	406	575	216	315	45	845	28	2-M63x1.5	1215	80	M20x42	170	22	71.0
315M	2	508	120	635	645	457	685	216	315	45	845	28	2-M63x1.5	1295	65	M20x42	140	18	58.0
315M	4-8	508	120	635	645	457	685	216	315	45	845	28	2-M63x1.5	1325	80	M20x42	170	22	71.0
315L	2	508	120	635	645	508	685	216	315	45	845	28	2-M63x1.5	1295	65	M20x42	140	18	58.0
315L	4-8	508	120	635	645	508	685	216	315	45	845	28	2-M63x1.5	1325	80	M20x42	170	22	71.0
355M	2	610	120	730	710	560	750	254	355	52	1010	28	2-M63x1.5	1500	75	M24x50	140	20	67.5
355M	4-8	610	120	730	710	560	750	254	355	52	1010	28	2-M63x1.5	1530	100	M24x50	210	28	90.0
355L	2	610	120	730	710	630	750	254	355	52	1010	28	2-M63x1.5	1500	75	M24x50	140	20	67.5
355L	4-8	610	120	730	710	630	750	254	355	52	1010	28	2-M63x1.5	1530	100	M24x50	210	28	90.0

* Shaft end tolerances: k6 up to D. 48. The rest, m6.

IM B5 / IM 3001						
Frame	P	N	M	S	T	LA
160	350	250	300	19	5	15
180	350	250	300	19	5	15
200	400	300	350	19	5	17
225	450	350	400	19	5	19
250	550	450	500	19	5	20
280	550	450	500	19	5	22
315	660	550	600	24	6	24
355	800	680	740	24	6	25

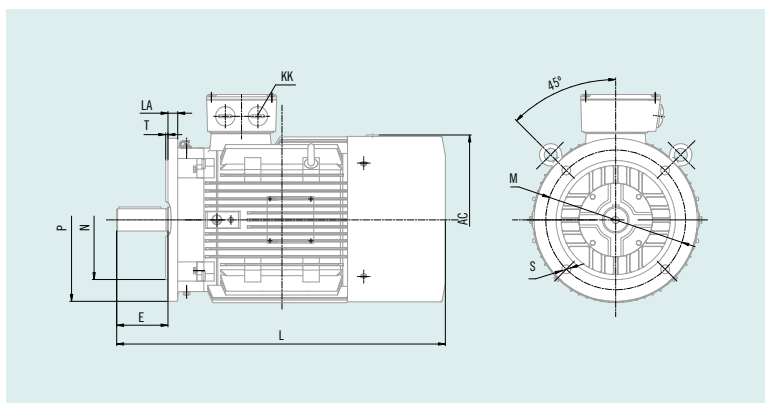

* Frames 160, 180 and 200, 4 holes 45°. The rest, 8 holes 22.5°.

* Dimensions change depending on the motor series. Please contact to Cosgra for further information. EGQ dimensions.

SINGLE-PHASE ASYNCHRONOUS MOTORS

Aluminium motors **MY/MYT** series.
Mounting positions
B3 - B5 - B5R - B14 - B14G.

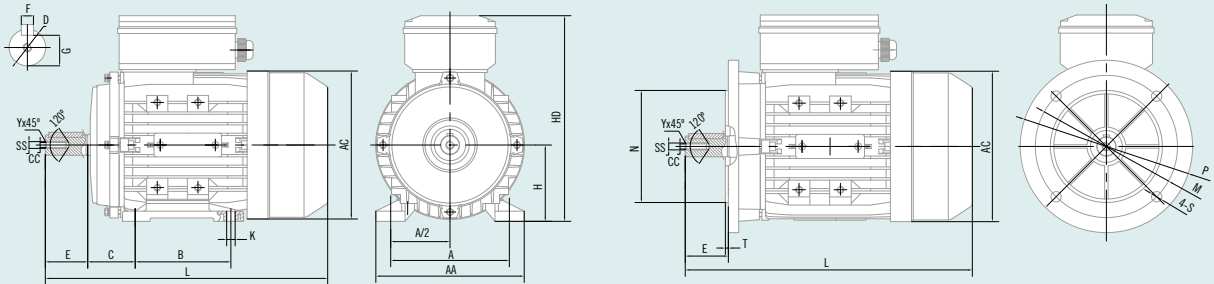

IM B3 / IM 1001										SHAFT END Tolerance k6					IM B5 / IM 3001 4 holes 45°				
Frame	A	AA	AC	B	C	H	HD	K	L	D	SS	E	F	G	M	N	P	S	T
56	90	110	115	71	36	56	156	5.8x5	192	9	M3	20	3	7.2	100	80	120	7	3.0
63	100	120	130	80	40	63	179	7x10	230	11	M4	23	4	8.5	115	95	140	10	3.0
71	112	132	145	90	45	71	194	7x10	260	14	M5	30	5	11.0	130	110	160	10	3.5
80	125	160	165	100	50	80	223	10x13	295	19	M6	40	6	15.5	165	130	200	12	3.5
90S	140	175	185	100	56	90	240	10x13	315	24	M8	50	8	20.0	165	130	200	12	3.5
90L	140	175	185	125	56	90	240	10x13	365	24	M8	50	8	20.0	165	130	200	12	3.5
100	160	198	205	140	63	100	260	12x15	400	28	M10	60	8	24.0	215	180	250	15	4.0

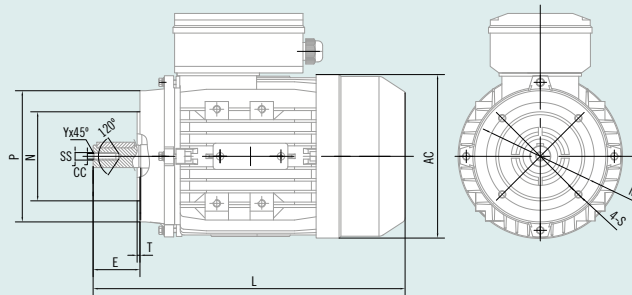

IM B5R 4 holes 45°						IM B14 / IM 3601 4 holes 45°						IM B14G / IM 3601 G 4 holes 45°					
Frame	M	N	P	S	T	Frame	M	N	P	S	T	Frame	M	N	P	S	T
56	NON AVAILABLE					56	65	50	80	M5	2.5	56	NON AVAILABLE				
63	NON AVAILABLE					63	75	60	90	M5	2.5	63	100	80	120	M6	2.5
71	115	95	140	10	3.0	71	85	70	105	M6	2.5	71	115	95	140	M8	3.0
80	130	110	160	12	3.5	80	100	80	120	M6	3.0	80	130	110	160	M8	3.5
90	130	110	160	12	3.5	90	115	95	140	M8	3.0	90	130	110	160	M8	3.5
100	165	130	200	15	3.5	100	130	110	160	M8	3.5	100	165	130	200	M10	3.5

* Dimensions change depending on the motor series. Please contact to Cosgra for further information. MY/MYT dimensions.

Double capacitor (centrifugal switch)

SINGLE-PHASE ASYNCHRONOUS MOTORS

Aluminium motors **ML** series.
Mounting positions
B3 - B5 - B5R - B14 - B14G.

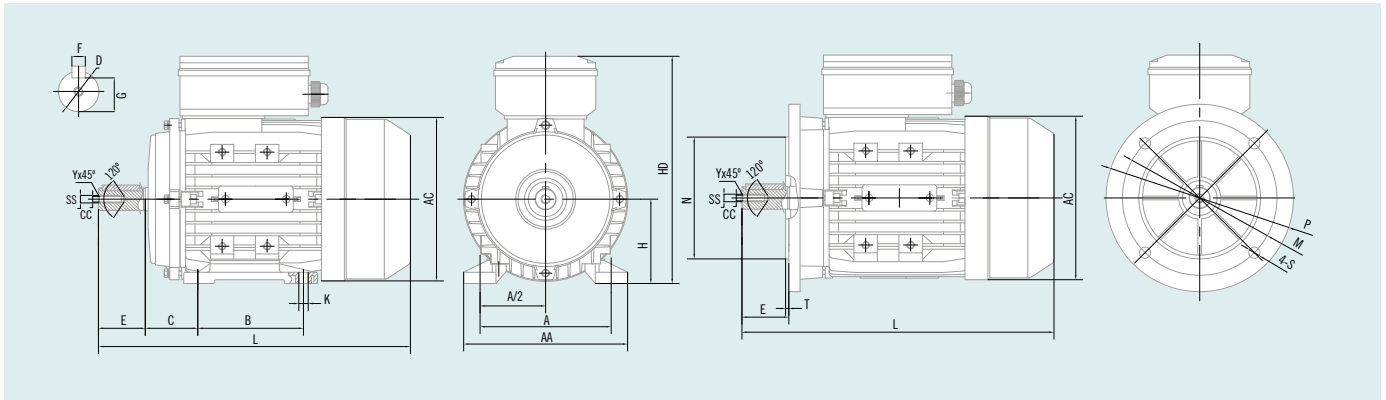

IM B3 / IM 1001										SHAFT END Tolerance k6					IM B5 / IM 3001 4 holes 45°				
Frame	A	AA	AC	B	C	H	HD	K	L	D	SS	E	F	G	M	N	P	S	T
71	112	132	145	90	45	71	194	7X10	260	14	M5	30	5	11.0	130	110	160	10	3.5
80	125	157	165	100	50	80	223	10X13	295	19	M6	40	6	15.5	165	130	200	12	3.5
90S	140	172	185	100	56	90	240	10X13	315	24	M8	50	8	20.0	165	130	200	12	3.5
90L	140	172	185	125	56	90	240	10X13	335/365	24	M8	50	8	20.0	165	130	200	12	3.5
100L	160	196	205	140	63	100	260	12X15	400	28	M10	60	8	24.0	215	180	250	15	4.0
112M	190	222	230	140	70	112	295	12X15	430	28	M10	60	8	24.0	215	180	250	15	4.0

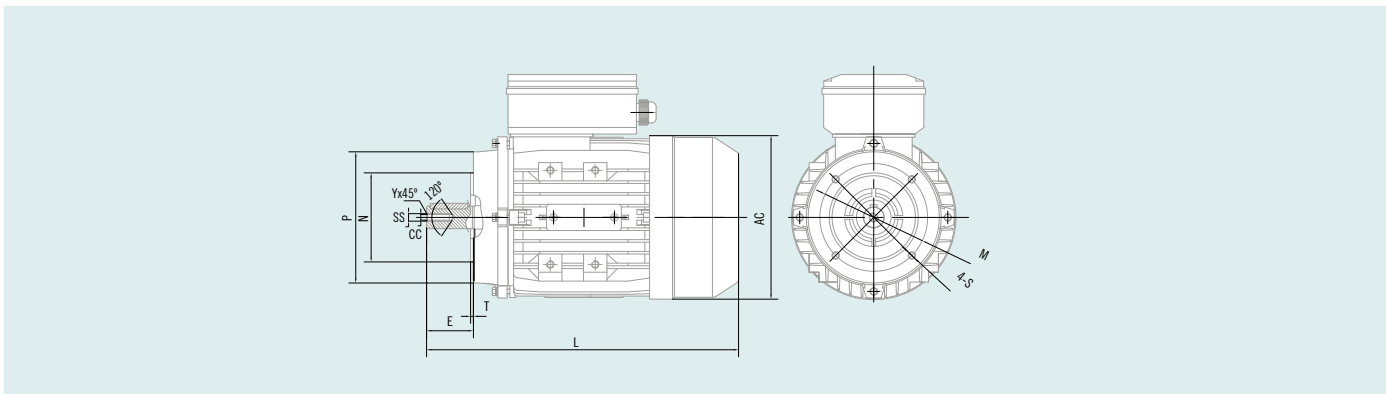

IM B5R 4 holes 45°					IM B14 / IM 3601 4 holes 45°					IM B14G / IM 3601 G 4 holes 45°							
Frame	M	N	P	S	T	Frame	M	N	P	S	T	Frame	M	N	P	S	T
71	115	95	140	10	3.0	71	85	70	105	M6	2.5	71	115	95	140	M8	3.0
80	130	110	160	12	3.5	80	100	80	120	M6	3.0	80	130	110	160	M8	3.5
90	130	110	160	12	3.5	90	115	95	140	M8	3.0	90	130	110	160	M8	3.5
100	165	130	200	15	3.5	100	130	110	160	M8	3.5	100	165	130	200	M10	3.5
112	165	130	200	15	3.5	112	130	110	160	M8	3.5	112	165	130	200	M10	3.5

* Dimensions change depending on the motor series. Please contact to Cosgra for further information. ML dimensions.

ELECTROMAGNETIC BRAKE MOTORS

Aluminium motors **IE1-MSEF** series.
Mounting positions **B3 - B5 - B5R - B14 - B14G**.

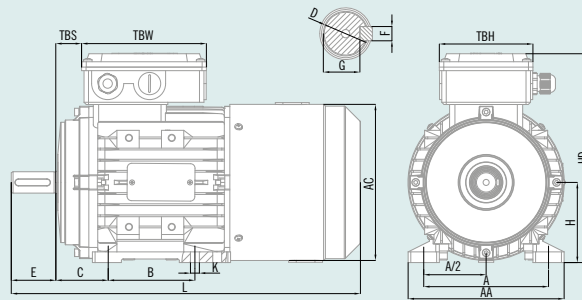

IM B3 / IM 1001														SHAFT END Tolerance j6						
Frame	A	AA	AC	B	C	H	HD	K	KK	L	TBS	TBW	TBH	D	E	F	G	SS	XX	ZZ
63	100	120	130	80	40	63	178	7x10	1-M16x1.5	275	19	120	94	11	23	4	8.5	M4	10	14
71	112	132	147	90	45	71	190	7x10	1-M20x1.5	320	25	120	94	14	30	5	11.0	M5	12	17
80	125	160	163	100	50	80	220	10x13	1-M20x1.5	355	26	140	105	19	40	6	15.5	M6	16	21
90S	140	175	183	100	56	90	235	10x13	1-M20x1.5	365	30	140	105	24	50	8	20.0	M8	19	25
90L1	140	175	183	125	56	90	235	10x13	1-M20x1.5	395	30	140	105	24	50	8	20.0	M8	19	25
90L2	140	175	183	125	56	90	235	10x13	1-M20x1.5	395	30	140	105	24	50	8	20.0	M8	19	25
100*	160	198	205	140	63	100	258	12x15	2-M20x1.5	462	28	140	105	28	60	8	24.0	M10	22	30
112	190	220	229	140	70	112	286	12x15	2-M25x1.5	475	36	160	115	28	60	8	24.0	M10	22	30
132S	216	252	265	140	89	132	330	12x15	2-M25x1.5	535	43	160	115	38	80	10	33.0	M12	28	37
132M	216	252	265	178	89	132	330	12x15	2-M25x1.5	574	43	160	115	38	80	10	33.0	M12	28	37
132L	216	252	265	178	89	132	330	12x15	2-M25x1.5	574	43	160	115	38	80	10	33.0	M12	28	37
160M	254	290	325	210	108	160	388	15x19	2-M32x1.5	725	64	145	145	42	110	12	37.0	M16	36	45
160L	254	290	325	254	108	160	388	15x19	2-M32x1.5	725	64	145	145	42	110	12	37.0	M16	36	45

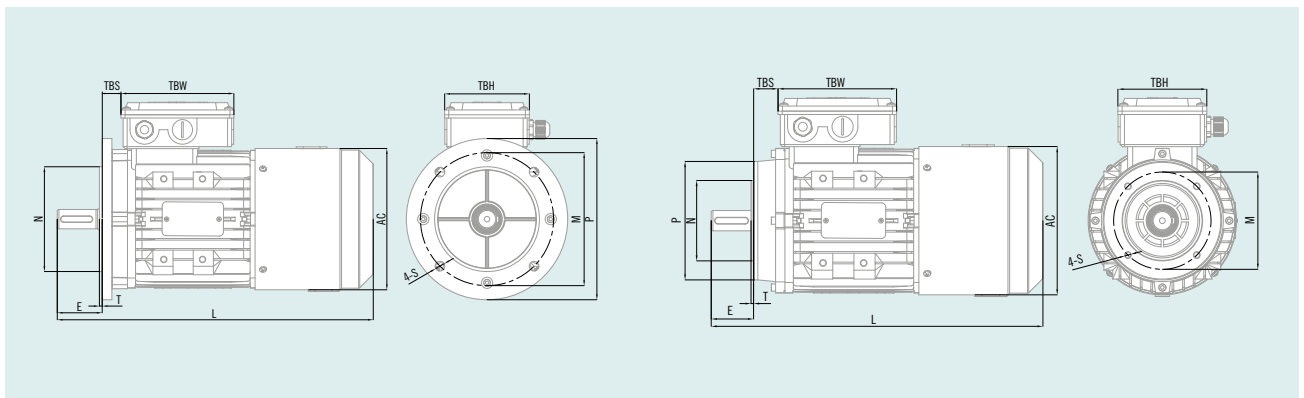

Frame	IM B5 / IM 3001 4 holes 45°					IM B5R 4 holes 45°					IM B14 / IM 3601 4 holes 45°					IM B14G / IM 3601 G 4 holes 45°				
	M	N	P	S	T	M	N	P	S	T	M	N	P	S	T	M	N	P	S	T
63	115	95	140	10	3.0	NON AVAILABLE					75	60	90	M5	2.5	100	80	120	M6	2.5
71	130	110	160	10	3.5	115	95	140	10	3.0	85	70	105	M6	2.5	115	95	140	M8	3.0
80	165	130	200	12	3.5	130	110	160	10	3.5	100	80	120	M6	3.0	130	110	160	M8	3.5
90	165	130	200	12	3.5	130	110	160	10	3.5	115	95	140	M8	3.0	130	110	160	M8	3.5
100	215	180	250	15	4.0	165	130	200	12	3.5	130	110	160	M8	3.5	165	130	200	M10	3.5
112	215	180	250	15	4.0	165	130	200	12	3.5	130	110	160	M8	3.5	165	130	200	M10	3.5
132	265	230	300	15	4.0	215	180	250	15	4.0	165	130	200	M10	4.0	215	180	250	M12	4.0
160	300	250	350	19	5.0	NON AVAILABLE					215	180	250	M12	4.0	NON AVAILABLE				

* Dimensions change depending on the motor series. Please contact to Cosgra for further information. MSE dimensions.

Forced ventilation

FORCED VENTILATION UNIT

G-D SERIES.
MOTOR FRAME SIZE **IEC63-IEC132**.

This kit ensures the cooling of motors driven by a frequency converter at low speeds and it reduces noise at high speeds. It's a compacted motor with an internal unit of aluminium and housing of steel sheet with priming paint.

The same unit allows a single-phase 230 V and a three-phase 230/400 V connection. This kit needs to be connected always separately from the motor connection. There is a specific forced ventilation kit for each frame size motor.

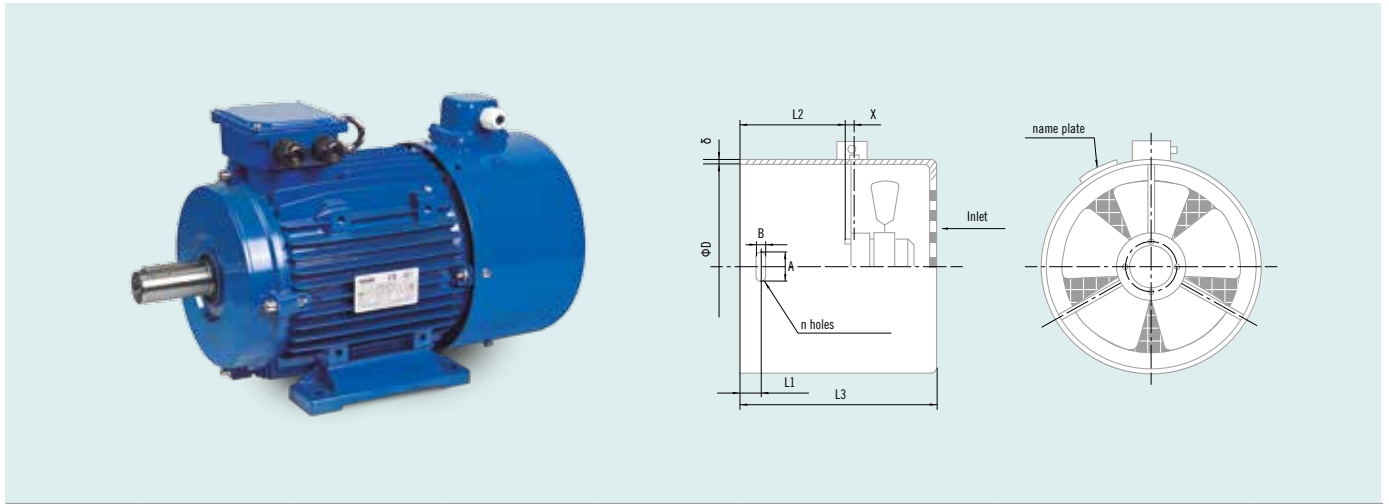

Type	ΦD	L1	X	L2	L3	δ	A	B	n
G-63D3	121 ⁺¹ ₀	8±1	7	67	157	1.2	12	6	4
G-71D3	138 ⁺¹ ₀	13±1	7	77	167	1.2	12	6	4
G-80D3	154 ⁺¹ ₀	16.5±1	7	93	183	1.5	12	6	4
G-90D3	173 ⁺¹ ₀	17±1	7	100	192	1.5	12	6	4
G-100D3	196 ⁺¹ ₀	19±1	10	98	198	1.5	14	7	4
G-112D3	219 ⁺¹ ₀	18.5±1	10	103	203	1.5	14	7	4
G-132D3	256 ⁺¹ ₀	18.5±1	10	122	229	1.5	14	7	4

Type		50 Hz			60 Hz		
		U (V)	I (A,max)	P (W)	U (V)	I (A,max)	P (W)
G-63D3	1 μF - 1~Δ	230	0.100	20	230	0.100	20
	3 ~ Δ	230	0.100	25	230	0.100	25
	3 ~ Y	400	0.057	25	400	0.060	25
G-71D3	1 μF - 1~Δ	230	0.120	25	230	0.100	20
	3 ~ Δ	230	0.120	30	230	0.100	25
	3 ~ Y	400	0.072	30	400	0.060	25
G-80D3	1 μF - 1~Δ	230	0.110	20	230	0.110	20
	3 ~ Δ	230	0.110	25	230	0.110	25
	3 ~ Y	400	0.065	25	400	0.065	25
G-90D3	1 μF - 1~Δ	230	0.100	20	230	0.100	22
	3 ~ Δ	230	0.100	25	230	0.090	25
	3 ~ Y	400	0.057	25	400	0.050	25
G-100D3	2 μF - 1~Δ	230	0.300	55	230	0.310	70
	3 ~ Δ	230	0.300	70	230	0.250	70
	3 ~ Y	400	0.175	70	400	0.150	70
G-112D3	2 μF - 1~Δ	230	0.330	75	230	0.400	95
	3 ~ Δ	230	0.330	85	230	0.300	95
	3 ~ Y	400	0.175	85	400	0.170	100
G-132D3	2 μF - 1~Δ	230	0.350	50	230	0.270	55
	3 ~ Δ	230	0.350	55	230	0.280	55
	3 ~ Y	400	0.210	55	400	0.170	55

FORCED VENTILATION UNIT

G-B SERIES.
MOTOR FRAME SIZE **IEC160 - IEC355**.

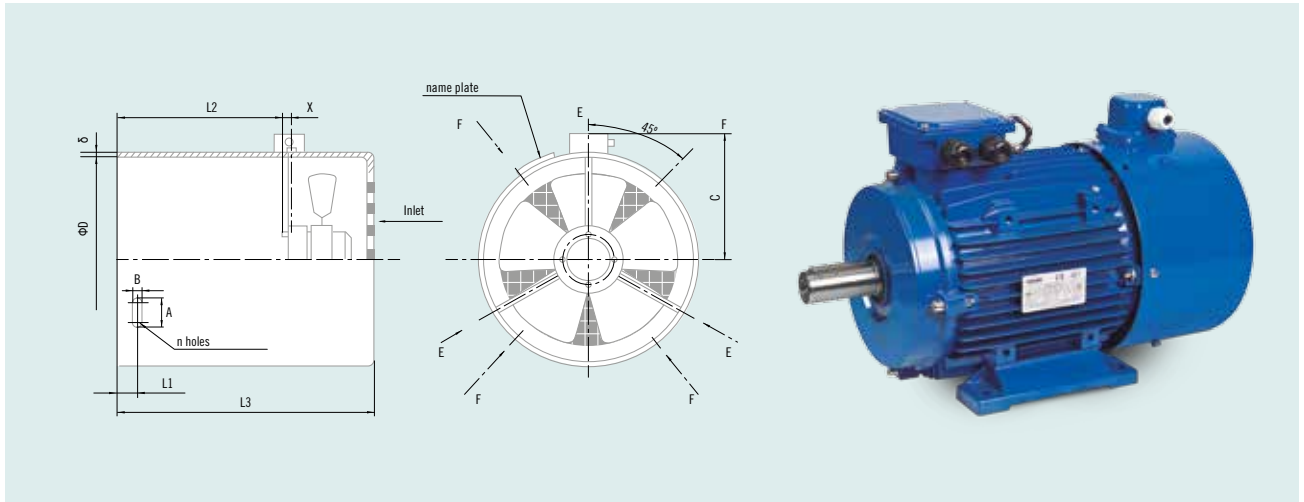

Type	ØD	L1	L2	X	L3	δ	A	B	n	C
G-160B3	311 ⁺¹ ₀	20±1	149	10	277	1.5	14	7	4	210
G-180B3	352 ⁺¹ ₀	35±1	190	10	312	1.5	14	7	4	231
G-200B3	393 ⁺¹ ₀	40±1	190	10	314	1.5	17	9	4	252
G-225B3	443 ⁺¹ ₀	45±1	220	12	374	2.0	17	9	4	276
G-250B3	482 ⁺¹ ₀	55±1	240	12	402	2.0	17	9	4	296
G-280B3	546 ⁺¹ ₀	65±1	265	12	429	2.0	25	11	4	362
G-315B3	614 ⁺¹ ₀	75±1	310	20	505	2.0	25	11	4	398
G-355B3	694 ⁺¹ ₀	82±1	380	20	585	2.5	25	13	4	437

Type		50 Hz			60 Hz		
		U(V)	I (A,max)	P (W)	U (V)	I (A,max)	P (W)
G-160B3	4µF - 1~Δ	230	0.37	65	230	0.36	80
	3 ~ Δ	230	0.37	65	230	0.36	80
	3 ~ Y	400	0.21	65	400	0.20	80
G-180B3	4µF - 1~Δ	230	0.42	85	230	0.43	110
	3 ~ Δ	230	0.39	85	230	0.39	110
	3 ~ Y	400	0.23	85	400	0.23	110
G-200B3	4µF - 1~Δ	230	0.50	100	230	0.55	125
	3 ~ Δ	230	0.40	105	230	0.40	125
	3 ~ Y	400	0.25	105	400	0.25	125
G-225B3	6µF - 1~Δ	230	0.50	85	230	0.50	100
	3 ~ Δ	230	0.50	85	230	0.45	90
	3 ~ Y	400	0.29	80	400	0.25	95
G-250B3	6µF - 1~Δ	230	0.90	120	230	1.00	145
	3 ~ Δ	230	0.90	90	230	0.55	230
	3 ~ Y	400	0.45	130	400	0.40	160
G-280B3	12µF - 1~Δ	230	1.00	180	230	1.10	240
	3 ~ Δ	230	0.90	180	230	0.90	240
	3 ~ Y	400	0.55	180	400	0.50	245
G-315B3	2µF - 1~Δ	230	1.90	450	230	2.66	535
	3 ~ Δ	230	1.70	450	230	1.05	535
	3 ~ Y	400	0.98	450	400	0.90	545
G-355B3	16µF - 1~Δ	230	2.20	650	230	3.10	650
	3 ~ Δ	230	2.20	650	230	2.42	745
	3 ~ Y	400	1.27	650	400	1.39	595

WARRANTIES, RETURNS AND COMPLAINTS

WARRANTIES

- **COSGRA** guarantees the motors it supplies against defective materials or manufacturing for a period of one year counted from the date of dispatch, taking the date given on the delivery note as valid, unless there is specific agreement in the offer or the acceptance of the order.
- Repairs are understood as taking place at **COSGRA'S** facilities, and the Purchaser will be responsible for paying the costs of dismantling, packaging, transport, Customs procedures, duties, etc. resulting from sending the equipment to **COSGRA'S** facilities and its subsequent delivery to the Purchaser.
- **COSGRA** may agree with the Purchaser to carry out repairs to defective parts or replacements at the Purchaser's facilities. **COSGRA** will not pay for repairs carried out by third parties.
- The warranty consists of the repair or replacement of the parts that are faulty due to defective material or manufacturing. If appropriate, the defective motor will be entirely replaced with a new one, and the transport and new dispatch costs paid.
- The repair or replacement of a defective part will not change the date of the beginning of the warranty period for the equipment supplied. However, the part replaced or repaired will have a year's warranty from its repair or replacement.
- Damage and the effects of normal wear and tear on the equipment are excluded from the warranty, as well as damage and defects caused by starting it up incorrectly, incorrect conservation or maintenance, erroneous storage or handling, modifications introduced without the written consent of **COSGRA**, and, in general, reasons not attributable to **COSGRA**.
- In all the circumstances set out in the above sections, **COSGRA** will not be responsible for defects in the motors and equipment supplied for more than one year from the date of dispatch.
- **COSGRA** will not under any circumstances be responsible for indirect and/or consequential damage that may occur as a result of the equipment supplied: loss of production, breakdowns or the cost of stoppages, etc.
- **COSGRA'S** full contractual responsibility deriving from the equipment supplied is limited to the value of the equipment supplied leading to the claim. This limitation will not apply to liability for direct injury to people or damage to property.
- The proper operation, conservation and maintenance of the equipment supplied is the exclusive responsibility and duty of care of the Purchaser or end user.

RETURNS AND COMPLAINTS

- **COSGRA** will not accept returns of equipment if they have not first been agreed with the Purchaser. A period of 15 days from receipt by the Purchaser of the goods supplied is established for it to notify **COSGRA** of its intention to return the equipment and the reason for this and to agree the procedure for returning it with **COSGRA**, as appropriate. Complaints from the Purchaser to **COSGRA** must always be made in writing and by reliable means.
- Transport costs must always be paid in cases of returns or dispatches of equipment to **COSGRA'S** facilities for refund, replacement or repair.
- **COSGRA** will not allow the return of equipment that has been used, fitted to other equipment or facilities, or dismantled without the involvement of **COSGRA**.
- **COSGRA** will not allow returns of products designed or manufactured specially for the order.



MECHANICAL SEALS FOR ROTARY SHAFTS

AC ELECTRIC MOTORS: Single-phase / Three-phase / Self-braking /
Anti-explosion / Flameproof / Variable speed

DRUM MOTORS AND MOTORIZED DRUMS

GEARBOXES: Worm gearbox / Pre-reduction / Double worm gearbox /
Planetary speed variators / Coaxials / Specific

Ctra. de Banyoles a Figueres, Km 9 _ Telf. - +34 972 597 807
Skype: cosgra.sa _ Fax +34 972 597 233
comercial@cosgra.com _ 17832 **CRESPiÀ** (Girona) _ SPAIN
Apartado 100 _ 17820 **BANYOLES** (Girona)
(E) Esponellà Latitude: 42°10'42.6"N Longitude: 2°48'04.9"E Altitude: 120 m.

Sociedad Comercial COSGRA LATAM S.P.A.

Alcalde Guzmán, 0121 - Quilicura - Santiago. **CHILE**
contacto@cosgra.cl
Telf: +56 944506061_+56 944644826_+56 956505381

www.cosgra.com

GRUP
CLME

TROTEN

CEMER

VEM

WA MOTORS

RAEL

UEB

JALMAC

YILMAZ